



INSTALLATION INSTRUCTIONS

MSD Pro-Billet Chevrolet Plug Dry Sump, PN 8512

Parts Included:

1 - Distributor Plug, PN 8512
1 - Gasket

2 - O-ring Seals

INSTALLATION

If any modifications have been done to the intake manifold, heads or deck of the block, the deck height may have changed. This will affect the position of the machined oil groove on the MSD Distributor Plug. The Slip Collar allows you to compensate for any of these changes.

It is important to ensure that the Plug is aligned properly. If the O-ring lands are positioned too low or high in the block the oil pressure will be affected. The O-rings will increase oil pressure by preventing oil from passing through the oil gallery lands.

Note: The engine block must be modified as shown to use the O-ring seals. If the block is not modified, the oil pressure will remain as if a standard distributor was used.

To set the position of the Slip Collar follow one of these procedures:

- Measure the position of the mounting collar from the old distributor.
- Use MSD's 3-In-1 Tool. (This tool also allows you to set gear mesh, oil pump shaft length and the slip collar height on wet sump applications.)
- Visually check the position of the Plug's lands through the access hole at the rear of the block on the passenger side of the oil gallery.

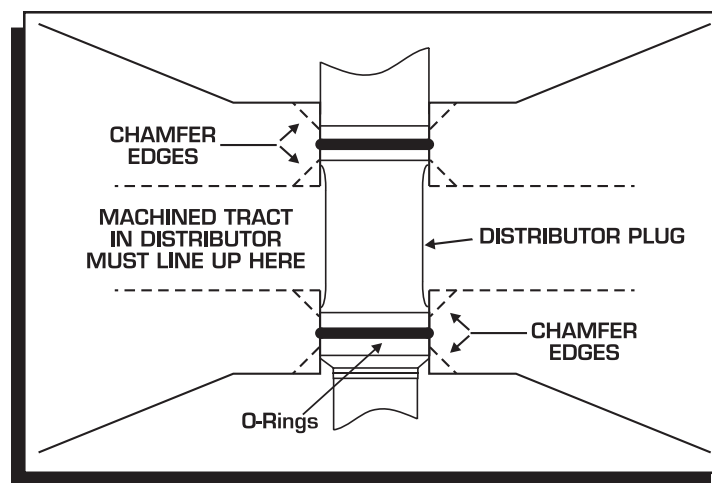

Figure 1 Alignment Of The Distributor Plug.



INSTALLATION INSTRUCTIONS

Service

In case of malfunction, this MSD component will be repaired free of charge according to the terms of the warranty. When returning MSD components for service, Proof of Purchase must be supplied for warranty verification. After the warranty period has expired, repair service is charged based on a minimum and maximum charge.

Send the unit prepaid with proof of purchase to the attention of: **Customer Service Department, Autotronic Controls Corporation, 12120 Esther Lama, Suite 114, El Paso, Texas 79936.**

When returning the unit for repair, leave all wires at the length in which you have them installed. Be sure to include a detailed account of any problems experienced, and what components and accessories are installed on the vehicle.

The repaired unit will be returned as soon as possible after receipt, COD for any charges. (Ground shipping is covered by warranty). All units are returned regular UPS unless otherwise noted. For more information, call the MSD Customer Service Line (915) 855-7123. MSD technicians are available from 8:00 a.m. to 5:00 p.m. Monday - Friday (Mountain Time).

Limited Warranty

Autotronic Controls Corporation warrants MSD Ignition products to be free from defects in material and workmanship under normal use and if properly installed for a period of one year from date of purchase. If found to be defective as mentioned above, it will be replaced or repaired if returned prepaid along with proof of date of purchase. This shall constitute the sole remedy of the purchaser and the sole liability of Autotronic Controls Corporation. To the extent permitted by law, the foregoing is exclusive and in lieu of all other warranties or representations whether expressed or implied, including any implied warranty of merchantability or fitness. In no event shall Autotronic Controls Corporation be liable for special or consequential damages.