

# **MSD** **IGNITION** **INSTALLATION INSTRUCTIONS**

## **MSD Pro-Billet Honda Distributor PN 8488**

**IMPORTANT:** Read the instructions before attempting the installation.

### **Parts Included:**

- 1 - Honda Distributor
- 1 - Parts Bag
- 1 - Wire Retainer
- 5 - 90° Boots and Terminals

- 1 - Mini-Stripper-Crimper Tool

### **Components Required:**

- 1 - SC Coil Driver, PN 6305
- 1 - Blaster SC Coil, PN 8235

**WARNING:** During installation, disconnect the battery cables. When disconnecting the battery, always remove the Negative cable first and install it last.

**WARNING:** The Blaster SC Coil and Coil Driver produce very high voltage and current. Use caution during installation and while working near the Coil assembly.

**Note:** The MSD Distributor Cap requires spark plug style 90° terminals and boots, which are supplied. MSD also offers complete wire sets with the correct terminals and lengths. For more information, contact MSD or go to [www.msdisignition.com](http://www.msdisignition.com).

The MSD Pro-Billet Honda Distributor **must** be used with the SC Coil Driver, PN 6305, and Blaster SC Coil, PN 8235. An MSD SCI, 6-Series and 7-Series Ignition Control may be used, but not required.

### **REMOVAL**

**IMPORTANT:** Check and establish the ignition timing prior to removing the original distributor.

1. Clean the area around the distributor and the engine to remove any loose debris. Disconnect the distributor connector.
2. Mark the location of each spark plug wire, then remove the wires from the distributor (Figure 1).
3. Remove the three 12mm bolts that secure the distributor to the engine. Remove the distributor by pulling it straight out of the engine.

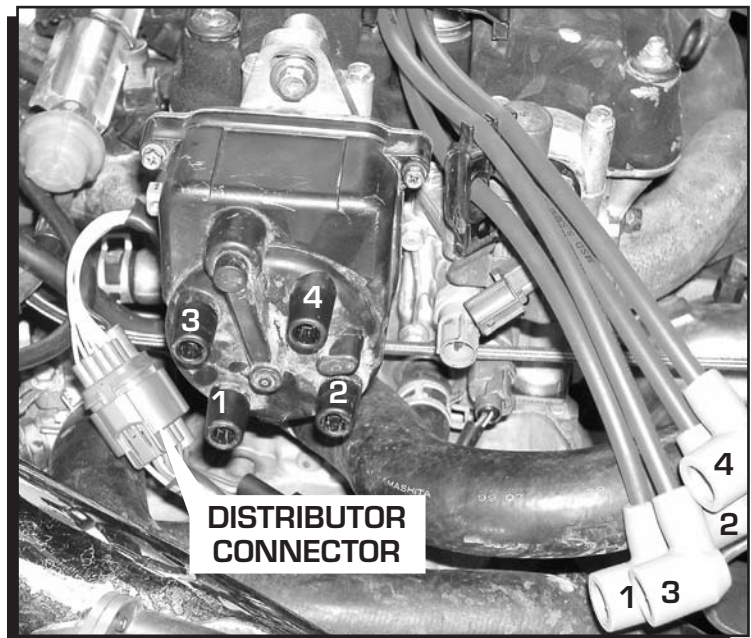

**Figure 1 Removing the Wires and Factory Distributor.**

## INSTALLATION

1. Apply a film of oil to the new O-ring and install it to the base of the distributor.
2. Note the distributor drive. It has two offset tabs that allow the distributor to be installed only in the correct position (Figure 2). Line up these tabs with those of the camshaft and install the distributor into the engine.
3. Install the three 12mm bolts to secure the distributor to the engine. Do not tighten them at this time (The timing will require adjustment ).
4. Connect the distributor connector into the engine harness (Figure 3).
5. Connect the 4-pin Deutsch connector to the matching connector of the MSD Coil Driver (Figure 3). The factory tach will function without connecting the Blue auxiliary tach wire.
6. A set of terminals and boots have been supplied so most wires can be converted from the factory socket terminals to the improved terminals of the MSD Distributor. Install the spark plug wires making sure they are in the correct firing order. For Crimping Instructions, see the following procedure on page 3.
7. Install the MSD wire retainer with the supplied screws (Figure 3).
8. Start the engine and set the ignition timing to the factory specifications. Once set, torque the three distributor bolts to 16-18 lb-ft.

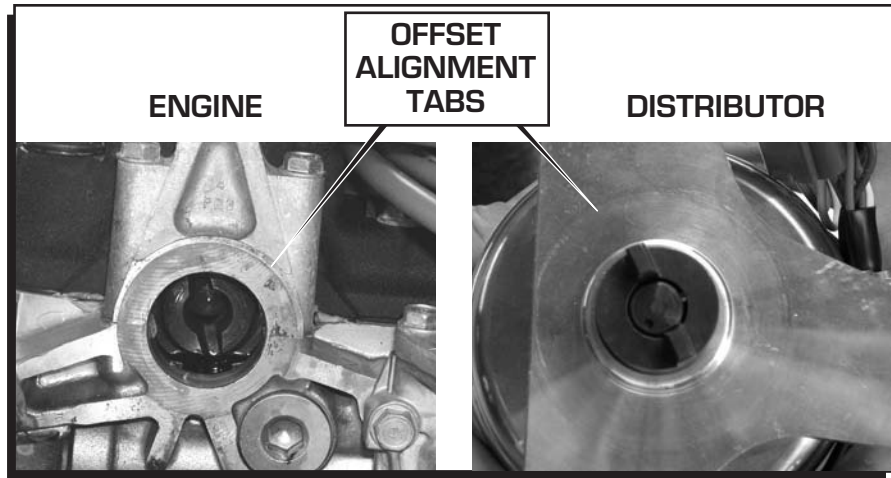

Figure 2 Aligning the Distributor and Camshaft.

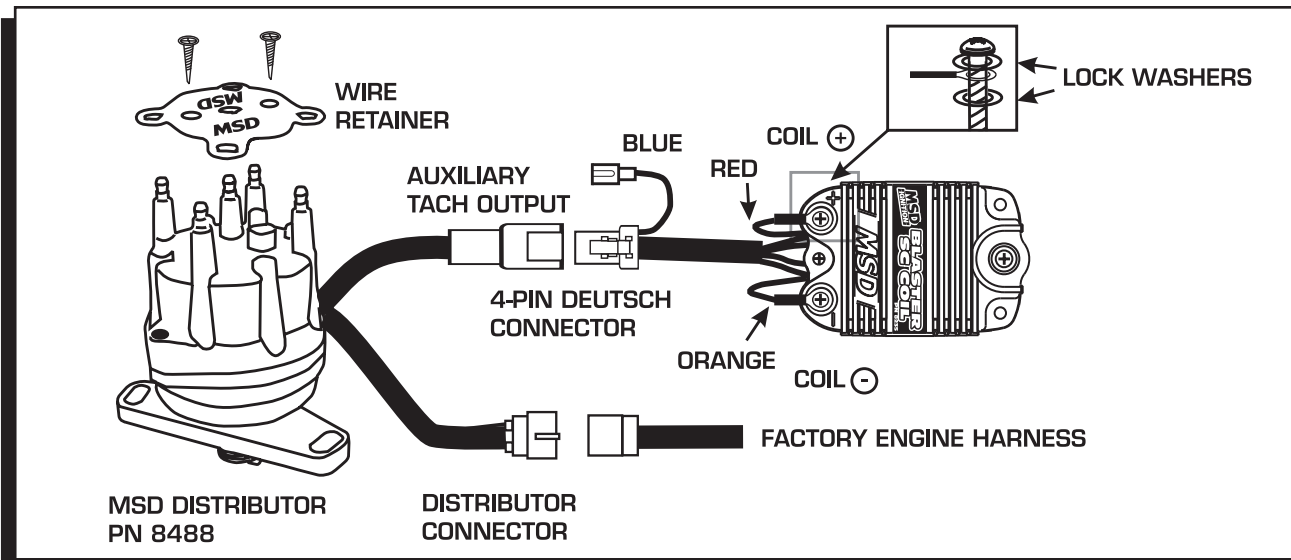
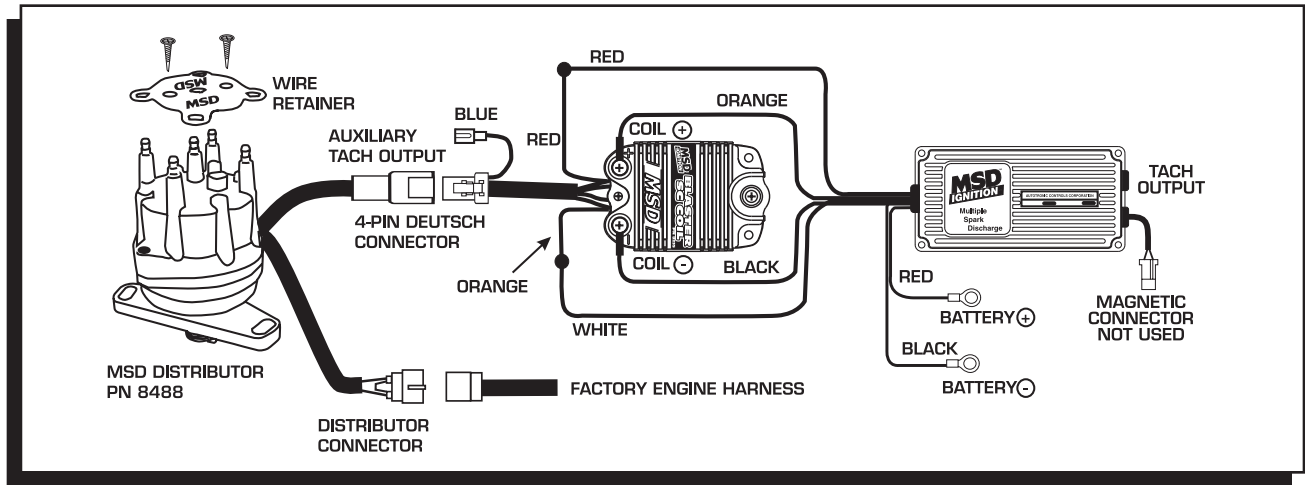

Figure 3 Wiring the Coil and Driver to the Distributor.

**WIRING AN MSD IGNITION CONTROL**

An MSD Ignition Control is not required but can be installed. Figure 4 shows the wiring when using an MSD CD Ignition Control such as an SCI, 6-Series or even an MSD 7-Series Ignition Control.



**Figure 4 Wiring the Coil and Driver with an MSD CD Ignition Control.**

**CRIMPING WITH THE MINI-STRIPPER-CRIMPER**

1. Slide the wire into the cutting die as shown in Figure 5.
2. After stripping the sleeve, position the wire in the terminal so the insulation protrudes about 1/8" beyond the insulation crimp tabs and the conductor extends about 1/8" past the conductor crimp tabs (Figure 6). Slide the other part of the Mini-Stripper-Crimper over the wire terminal and lightly press them together (Figure 7).
3. Position the wire and terminal into the "W" groove of the Mini-Stripper Crimper and follow Steps 4 - 6 to crimp the terminal to the sleeve.

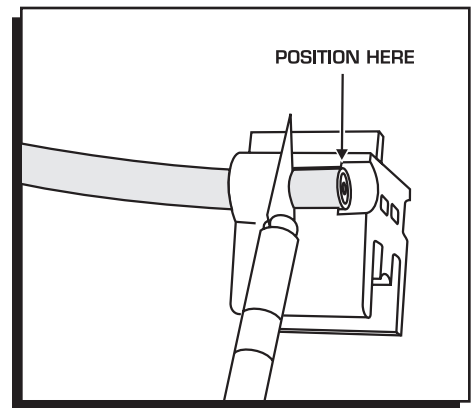

**Figure 5 Stripping the Sleeve.**

**Note:** It is normal for the conductor to retract into the insulation slightly as the sleeve crimp is made.

4. Put the assembly into a vise making sure the alignment tabs are on the outside edge of the vise jaws (Figure 8).
5. Slowly close the vise making sure the tool and terminal stay properly positioned and aligned (Figure 9). Stop applying pressure when the terminal ends have wrapped securely around the sleeve and grip the wire.

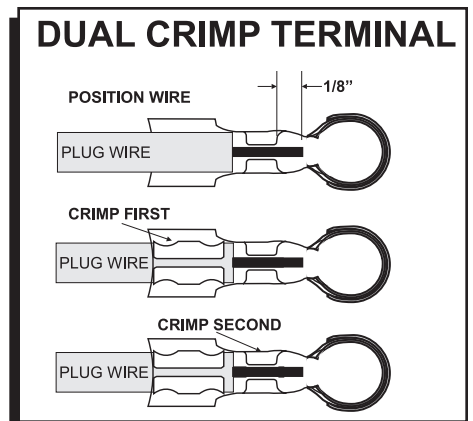

**Figure 6 Crimping a Dual Crimp Terminal.**

**Note:** DO NOT OVER CRIMP! It is possible to tear the sleeve of the wire by excessive pressure on the vise. This will cause a weaker crimp.

6. After the sleeve is crimped, push the conductor between the crimp tabs and use a set of needle-nose pliers to crimp them together. DO NOT OVER CRIMP.
7. Slide the boot over the terminal and install the wire.

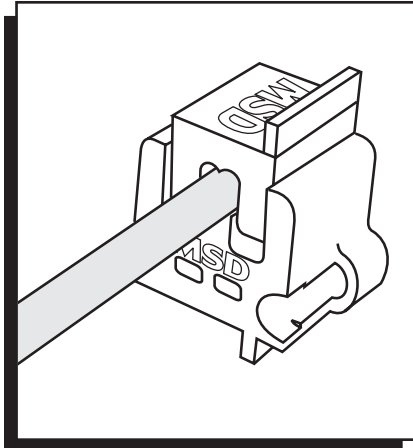

**Figure 7**  
**Aligning the Terminal in Tool.**

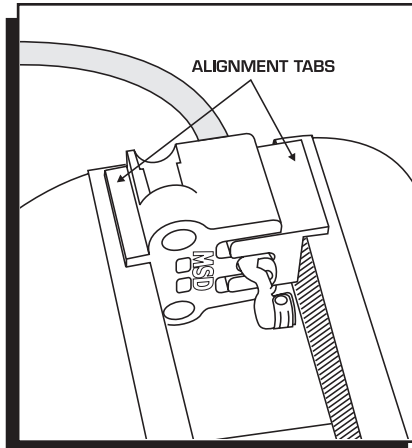

**Figure 8**  
**Preparing to Crimp in the Vise.**

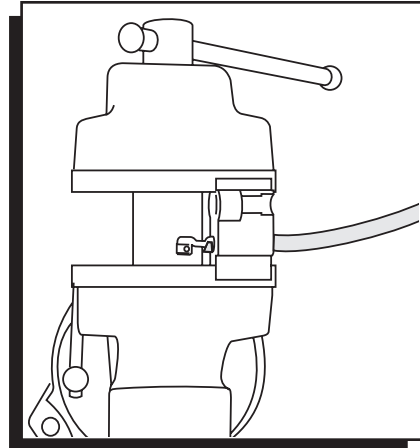

**Figure 9**  
**Crimping with the Vise.**

### Service

In case of malfunction, this MSD component will be repaired free of charge according to the terms of the warranty. When returning MSD components for warranty service, **Proof of Purchase** must be supplied for verification. After the warranty period has expired, repair service is based on a minimum and maximum fee.

**All returns must have a Return Material Authorization (RMA) number** issued to them before being returned. To obtain an RMA number please contact MSD Customer Service at 1 (888) MSD-7859 or visit our website at [www.msdisignition.com/rma](http://www.msdisignition.com/rma) to automatically obtain a number and shipping information.

When returning the unit for repair, leave all wires at the length in which you have them installed. Be sure to include a detailed account of any problems experienced, and what components and accessories are installed on the vehicle. The repaired unit will be returned as soon as possible using Ground shipping methods (ground shipping is covered by warranty). For more information, call MSD Ignition at (915) 855-7123. MSD technicians are available from 7:00 a.m. to 6:00 p.m. Monday - Friday (mountain time).

### Limited Warranty

MSD IGNITION warrants this product to be free from defects in material and workmanship under its intended normal use\*, when properly installed and purchased from an authorized MSD dealer, for a period of one year from the date of the original purchase. This warranty is void for any products purchased through auction websites. If found to be defective as mentioned above, it will be repaired or replaced at the option of MSD Ignition. Any item that is covered under this warranty will be returned free of charge using Ground shipping methods.

This shall constitute the sole remedy of the purchaser and the sole liability of MSD Ignition. To the extent permitted by law, the foregoing is exclusive and in lieu of all other warranties or representation whether expressed or implied, including any implied warranty of merchantability or fitness. In no event shall MSD Ignition or its suppliers be liable for special or consequential damages.

\*Intended normal use means that this item is being used as was originally intended and for the original application as sold by MSD Ignition. Any modifications to this item or if it is used on an application other than what MSD Ignition markets the product, the warranty will be void. It is the sole responsibility of the customer to determine that this item will work for the application they are intending. MSD Ignition will accept no liability for custom applications.