

# **MSD** **IGNITION** **INSTALLATION INSTRUCTIONS**

## **Pro-Billet Late Model Ford Distributors** **5.0L, 1986-1993, PN 8456** **5.0L, 1994-1995, PN 8455** **351W (non-roller cam), PN 8453** **351W (with hydraulic roller cam), PN 8452** **351W (with hydraulic roller cam), 1994-1995, PN 8451**

### **Parts Included:**

1 - Distributor  
1 - Gear Lubricant  
1 - O-Ring

**WARNING:** During installation disconnect the battery cables. When disconnecting the battery, always remove negative cable first and install it last.

### **GEAR INFORMATION**

The Pro-Billet PN 8451, PN 8452, PN 8455 and PN 8456 Distributors are designed as a direct replacement for Ford EFI High Output engines and are equipped with a steel gear for the hydraulic roller camshaft.

The PN 8453 model is a replacement for 351W engines with a TFI Ignition module and is supplied with an iron gear (non-roller camshaft).

### **REMOVAL**

1. Remove the existing distributor cap without disconnecting any spark plug wires.
2. With the cap off, turn the engine over until the rotor is aimed at a fixed point on the engine or firewall. Note this position by making a mark (Figure 1).
3. Place the distributor cap back on and note which plug wire the rotor is pointing at. Mark the spark plug wires and remove the cap.
4. Disconnect the connector from the distributor's ignition module.
5. Loosen the distributor hold-down clamp and slide it out of the way.
6. Lift the distributor out of the engine. Note that the rotor rotates as you lift it out. This is due to the helical cut gear and should be taken into consideration when installing the new distributor.

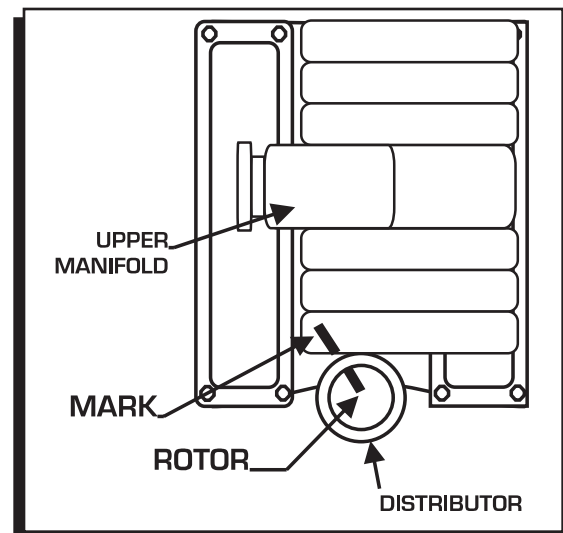

**Figure 1 Marking the Distributor Location.**

# **MSD** **IGNITION** **INSTALLATION INSTRUCTIONS**

## **INSTALLATION**

1. Install the new o-ring.
2. Remove the cap from the MSD distributor.
3. Apply a liberal amount of the supplied break-in lubricant to the distributor gear.
4. Install the distributor making sure that the rotor comes to rest at the fixed mark. If the distributor will not fully seat you may need to rotate the oil pump shaft.
5. With the rotor in the correct position and the distributor fully seated, install the distributor clamp and tighten it.
6. Connect the wiring harness to the ignition module.
7. Install the distributor cap and install the spark plug wires one at a time to ensure correct location. The firing order of the Ford Mustang 5.0L and the 351W is: 1-3-7-2-6-5-4-8.  
**Note:** This firing order only applies to high output 5.0L engines with a hydraulic roller camshaft.
8. You will need to check the ignition timing to get it to exact specifications. To check the timing you need to disconnect the Spout connector. Follow the recommended procedure which should be outlined on the Emission Specification Decal in the engine compartment.

### **Service**

In case of malfunction, this MSD component will be repaired free of charge according to the terms of the warranty. When returning MSD components for warranty service, **Proof of Purchase** must be supplied for verification. After the warranty period has expired, repair service is based on a minimum and maximum fee.

**All returns must have a Return Material Authorization (RMA) number** issued to them before being returned. To obtain an RMA number please contact MSD Customer Service at 1 (888) MSD-7859 or visit our website at [www.msdisignition.com/rma](http://www.msdisignition.com/rma) to automatically obtain a number and shipping information.

When returning the unit for repair, leave all wires at the length in which you have them installed. Be sure to include a detailed account of any problems experienced, and what components and accessories are installed on the vehicle. The repaired unit will be returned as soon as possible using Ground shipping methods (ground shipping is covered by warranty). For more information, call MSD Ignition at (915) 855-7123. MSD technicians are available from 7:00 a.m. to 6:00 p.m. Monday - Friday (mountain time).

### **Limited Warranty**

MSD IGNITION warrants this product to be free from defects in material and workmanship under its intended normal use\*, when properly installed and purchased from an authorized MSD dealer, for a period of one year from the date of the original purchase. This warranty is void for any products purchased through auction websites. If found to be defective as mentioned above, it will be repaired or replaced at the option of MSD Ignition. Any item that is covered under this warranty will be returned free of charge using Ground shipping methods.

This shall constitute the sole remedy of the purchaser and the sole liability of MSD Ignition. To the extent permitted by law, the foregoing is exclusive and in lieu of all other warranties or representation whether expressed or implied, including any implied warranty of merchantability or fitness. In no event shall MSD Ignition or its suppliers be liable for special or consequential damages.

\*Intended normal use means that this item is being used as was originally intended and for the original application as sold by MSD Ignition. Any modifications to this item or if it is used on an application other than what MSD Ignition markets the product, the warranty will be void. It is the sole responsibility of the customer to determine that this item will work for the application they are intending. MSD Ignition will accept no liability for custom applications.