

MSD[®] IGNITION INSTALLATION INSTRUCTIONS

MSD Chevy Billet Distributor Base with Retarded Pickup PN 83561

Important: Read these instructions before attempting the installation.

Parts Included:

1 - Pro-Billet Distributor Base

The MSD Chevy Billet Distributor Base is designed to replace the original Dual Pickup Base on PN 8356, Chevy Pro-Billet Distributor.

To replace the original base, the Chevy Pro-Billet Distributor must be taken apart. Follow the instructions and the exploded view at right to disassemble the distributor, replace the base and reassemble the distributor.

1. Remove the roll pin and the distributor gear.
2. Pull the engine shaft and advance assembly out of the distributor housing.
3. Use a 5/32" Allen Wrench to remove the four screws holding the base to the distributor housing.
4. Remove the original base and replace with the new base.
5. Reassemble the distributor in the reverse order that it was disassembled.

WIRING THE DISTRIBUTOR

Proper polarity is very important when connecting an MSD Distributor to an MSD Ignition. Pay close attention to the polarity on the MSD Distributor and the MSD Ignition.

MSD PICKUP POLARITY

Orange/Black is Mag +
Violet/Black is Mag -

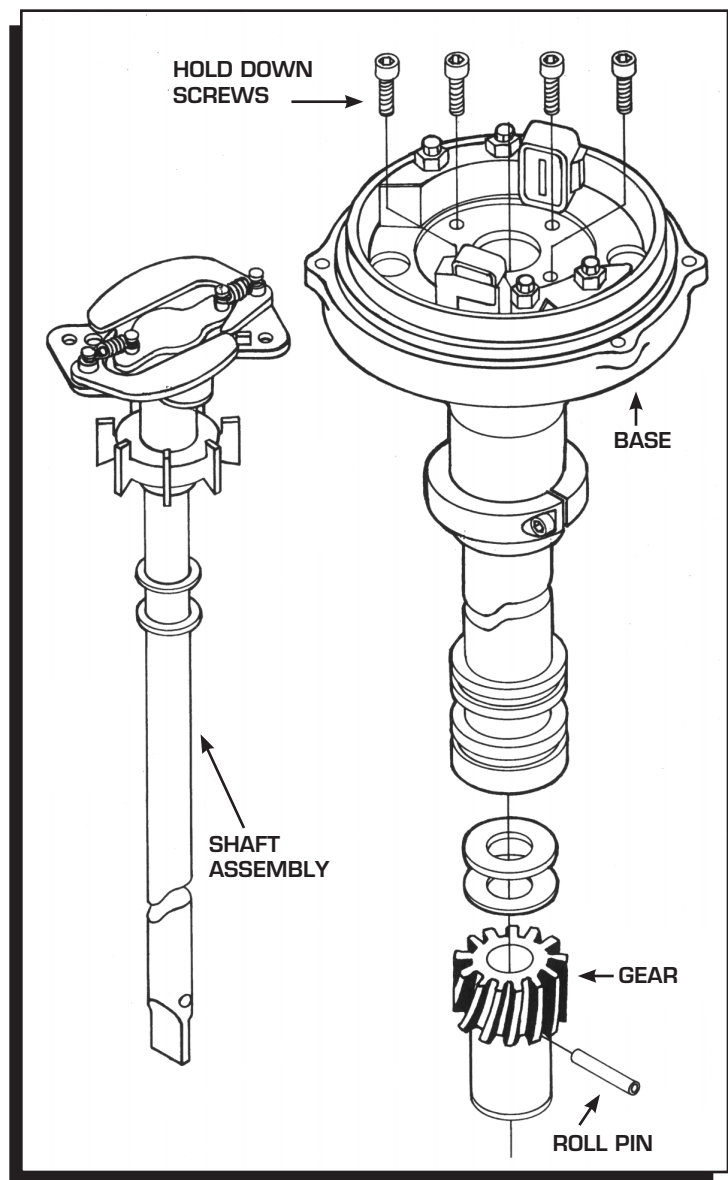

Figure 1 Disassembly.

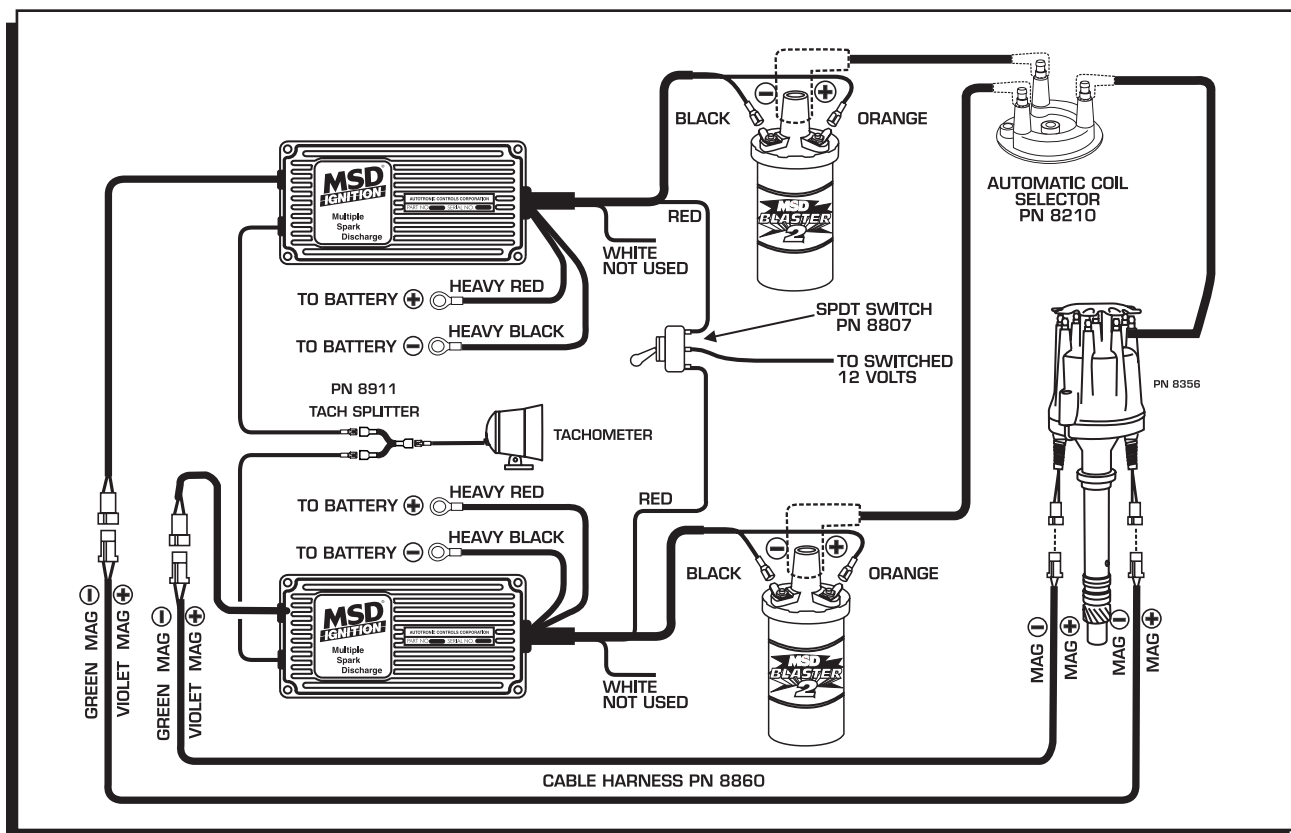

Figure 2 Wiring with MSD 6A Series Ignition Controls.

Service

In case of malfunction, this MSD component will be repaired free of charge according to the terms of the warranty. When returning MSD components for warranty service, **Proof of Purchase** must be supplied for verification. After the warranty period has expired, repair service is based on a minimum and maximum fee.

All returns must have a Return Material Authorization (RMA) number issued to them before being returned. To obtain an RMA number please contact MSD Customer Service at 1 (888) MSD-7859 or visit our website at www.msdisignition.com/rma to automatically obtain a number and shipping information.

When returning the unit for repair, leave all wires at the length in which you have them installed. Be sure to include a detailed account of any problems experienced, and what components and accessories are installed on the vehicle. The repaired unit will be returned as soon as possible using Ground shipping methods (ground shipping is covered by warranty). For more information, call MSD Ignition at (915) 855-7123. MSD technicians are available from 7:00 a.m. to 6:00 p.m. Monday - Friday (mountain time).

Limited Warranty

MSD IGNITION warrants this product to be free from defects in material and workmanship under its intended normal use*, when properly installed and purchased from an authorized MSD dealer, for a period of one year from the date of the original purchase. This warranty is void for any products purchased through auction websites. If found to be defective as mentioned above, it will be repaired or replaced at the option of MSD Ignition. Any item that is covered under this warranty will be returned free of charge using Ground shipping methods.

This shall constitute the sole remedy of the purchaser and the sole liability of MSD Ignition. To the extent permitted by law, the foregoing is exclusive and in lieu of all other warranties or representation whether expressed or implied, including any implied warranty of merchantability or fitness. In no event shall MSD Ignition or its suppliers be liable for special or consequential damages.

*Intended normal use means that this item is being used as was originally intended and for the original application as sold by MSD Ignition. Any modifications to this item or if it is used on an application other than what MSD Ignition markets the product, the warranty will be void. It is the sole responsibility of the customer to determine that this item will work for the application they are intending. MSD Ignition will accept no liability for custom applications.