

MSD[®] IGNITION INSTALLATION INSTRUCTIONS

MSD 6-Offroad Ignition Control PN 6470

Parts Included:

1 - MSD 6-Offroad Ignition, PN 6470	1 - Coil Harness
4 - Self Tapping Screws	4 - Faston Connectors
1 - Harness Assembly, PN 64601	3 - Wire Splice Devices
4 - Vibration Mounts	

WARNING: During installation, disconnect the battery cables. When disconnecting the battery, always remove the Negative cable first and install it last.

MOUNTING

The 6-Offroad Ignition may be mounted in any position and is designed to withstand underhood conditions. However, the unit should be mounted clear of direct engine heat sources. When mounting the Ignition, make sure the wiring harnesses reach their connections.

Use the Ignition as a template and mark the mounting holes. Remove the unit and drill the mounting holes using an 1/8" drill bit. Install the supplied vibration mounts to the Ignition, then mount the unit.

WIRING

Note: For more wiring information and troubleshooting tips, refer to the supplied MSD 6 Series Installation Instructions.

There are three Weathertight connectors on the MSD 6-Offroad Ignition Control:

6-Pin Connector: These wires are responsible for operating the MSD Ignition.

Red: Connects to a switched 12 volt source.

Orange: Connects to the Coil Positive (+) Terminal. **This is the only wire that connects to the Coil + terminal.**

Black: Connects to the Coil negative (-) Terminal. **This is the only wire that connects to the Coil - terminal.**

Violet: Connects to the magnetic pickup positive wire of the distributor.

Green: Connects to the magnetic pickup negative wire of the distributor.

Note: When the Violet and Green wires are used, the White wire should be sealed.

White: Connects to the points or electronic amplifier trigger signal.

Note: When the White wire is used, the Violet and Green wire should be sealed.

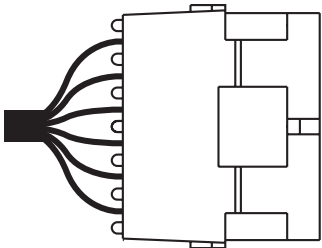

4-Pin Connector: The wires in this connector plug directly into the MSD Offroad Rev Control. If you are not using the Rev Control, seal these wires to prevent dirt, water and debris from entering the connector.

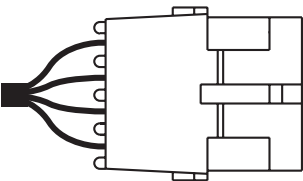

1-Pin Connector: This is the tach output signal wire and connects directly to the tachometer. It creates a square wave, 12 volt, 30% cycle signal.

Note: If your tach doesn't operate properly, see the Tachometer section of the 6 Series Instructions for more information.

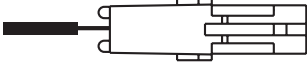

WIRING HARNESSSES

MSD offers direct plug-in wiring harnesses for several common applications. The 6-Offroad Ignition is supplied with four faston connectors that you install on the Ignition Harness, that will plug directly into the following Harnesses.

Ford TFI Ignition, PN 8874

GM Dual Connector Coil, PN 8876

GM 1996 - On, Single Connector Coil, PN 8877

Also, a Wiring Kit for Jeeps with an Integrated Coil/Ignition Module Assembly, PN 8813.

SPLICING AND CONNECTIONS

If your application requires splicing wires or other connections, always use the proper size connectors. Any connections should be soldered or sealed to prevent any chance of failure.

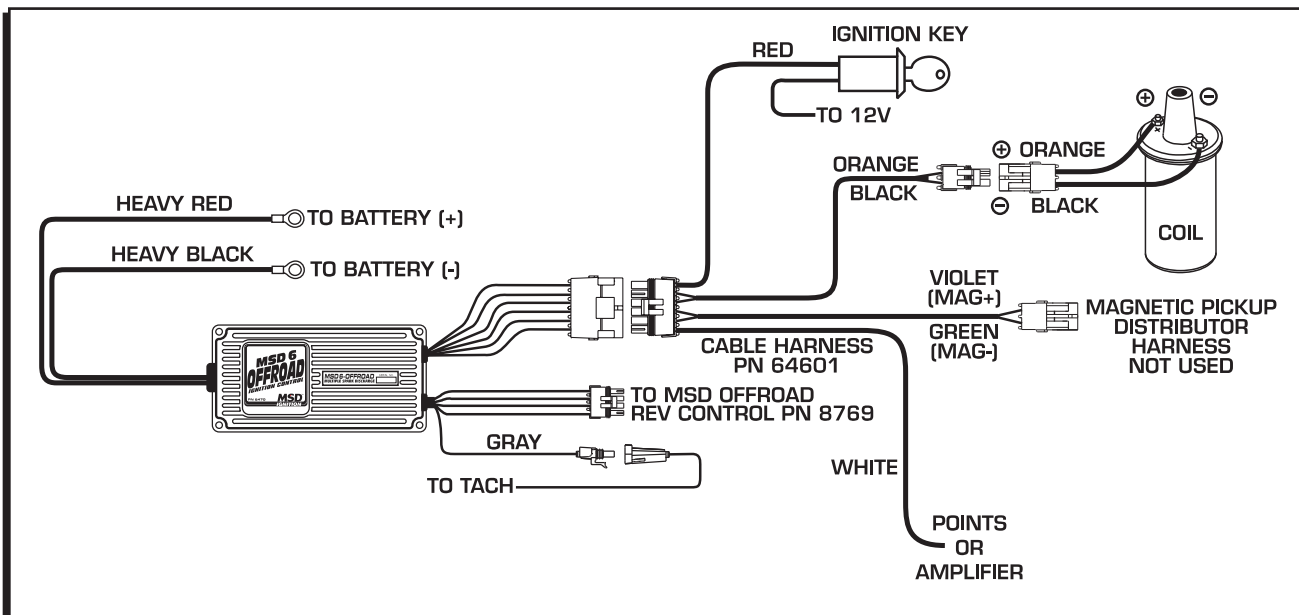

Figure 1 Wiring to a Stock Points or Amplifier Ignition System.

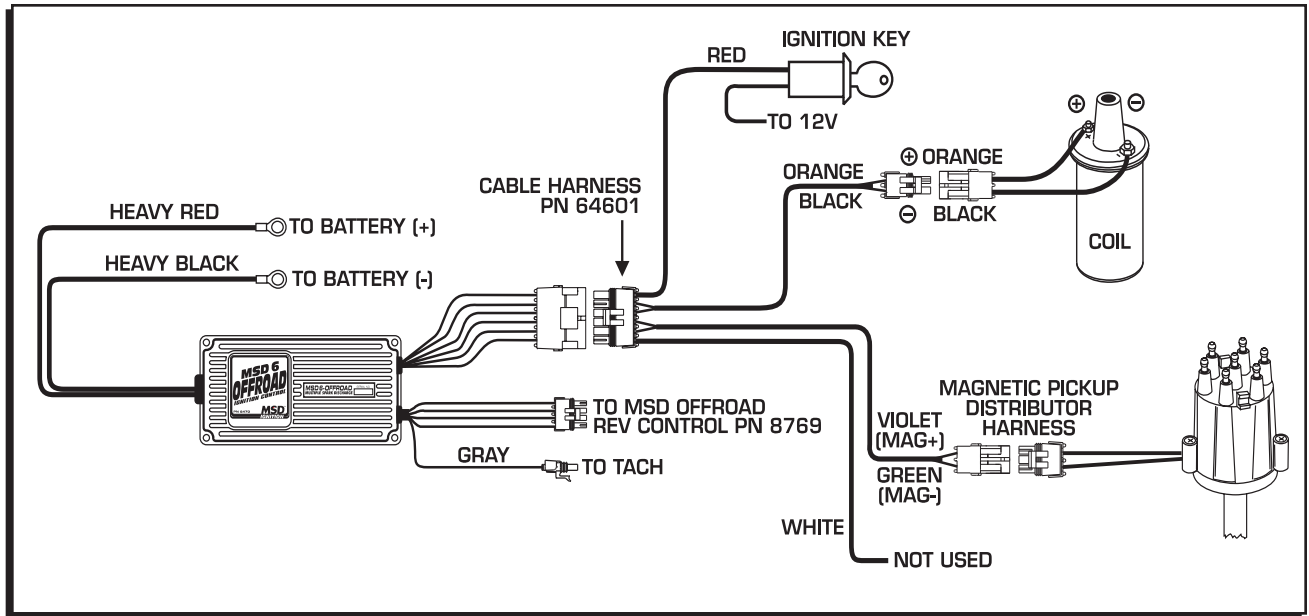

Figure 2 Wiring with an MSD Distributor.

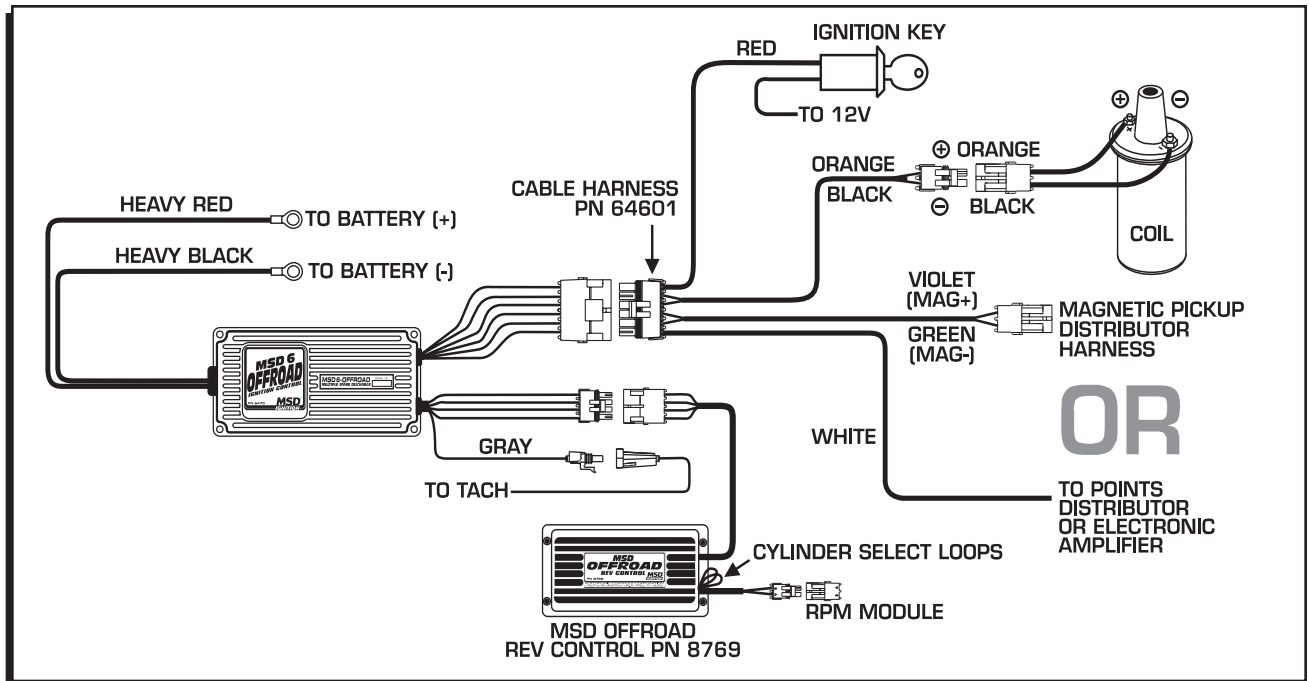

Figure 3 Wiring with the Offroad Rev Limiter.

