

MSD[®] **IGNITION** **INSTALLATION INSTRUCTIONS**

MSD Blaster Ignition PN 5900

Note: Read these instructions completely before attempting any installation.

Parts Included:

- 1 - Blaster Ignition, PN 5900
- 1 - Harness, PN 8860
- 1 - Harness, PN 8861
- 1 - 18" Ground wire
- 4 - Self Tapping Mounting Screws
- 1 - Parts Bag

MOUNTING

Mount the Blaster Ignition away from direct engine heat sources. Make sure the wires and harness can reach their connections. Using the unit as a template, mark the locations of the mounting holes. Remove the unit and use a 1/8" bit to drill the four holes. Use the four self tapping screws to mount the unit.

WIRING

The MSD Blaster Ignition is installed between the ignition coil and the triggering device. The Blaster is triggered by connecting either the **WHITE** wire or the Magnetic Pickup connector, **never both**. The **WHITE** wire is used to trigger through points or an electronic ignition. The magnetic pickup connector is used when using the magnetic pickup in the distributor.

The Blaster can only be used on inductive ignition systems.

Before attempting any wiring, find which diagram illustrates your vehicle's ignition system. In the installation, it is necessary to use the supplied wire splice devices.

Figure 1 shows the correct procedure for these splices.

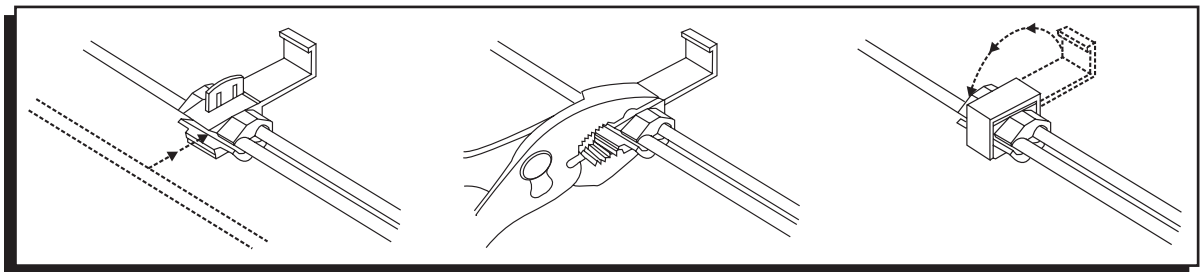

Figure 1 Using the Wire Splices.

The wires of the Blaster Ignition are color coded for easy installation.

RED	Switched 12 volt source.
ORANGE	Connects to coil negative.
BLACK	Connects to engine ground.
WHITE	Points or electronic ignition trigger
MAGNETIC PICKUP	2-Pin Connector
VIOLET	Positive (+)
GREEN	Negative (-)

Note: The White wire and magnetic pickup wiring will never be connected at the same time.

Figure 2 Wiring to a Points System.

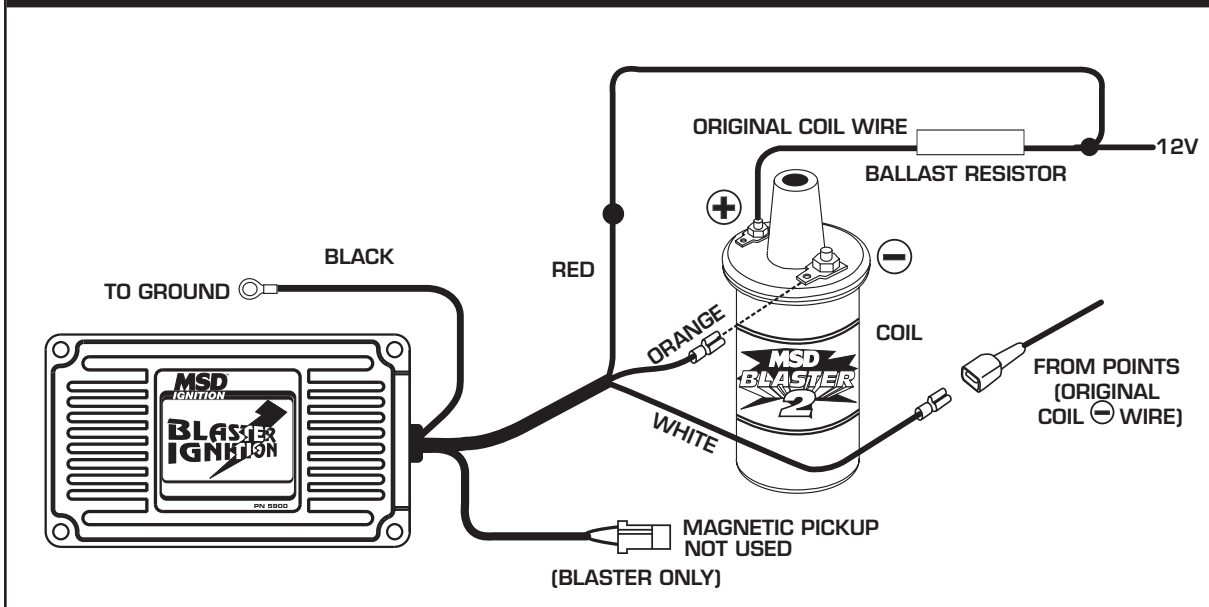

Figure 3 Wiring to an MSD Distributor.

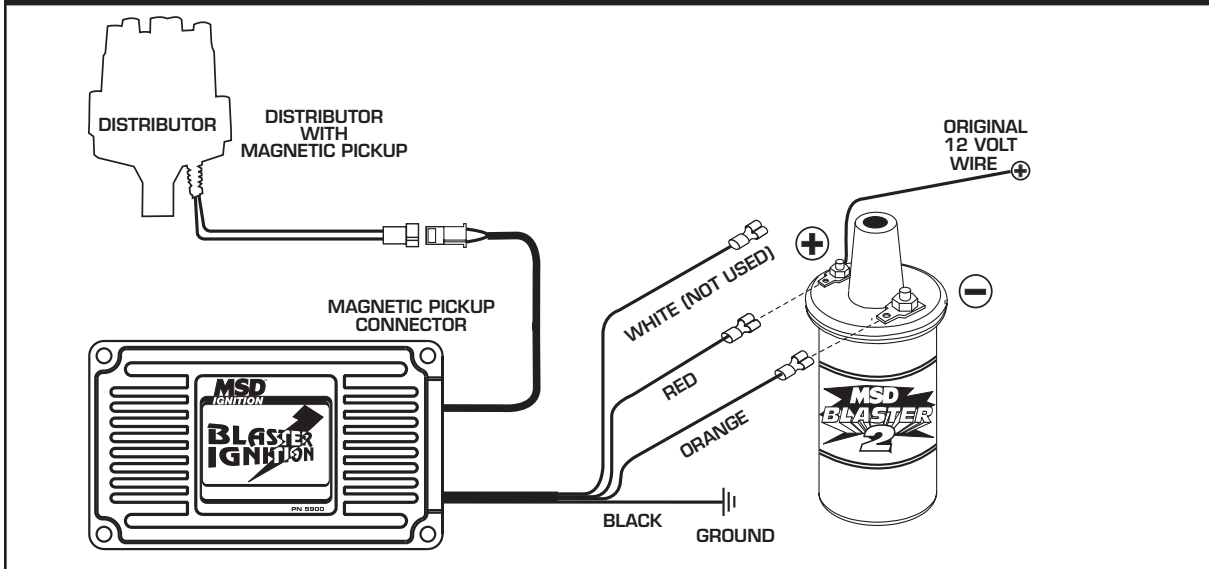

Figure 4 Wiring to a Factory Magnetic Pickup Distributor.

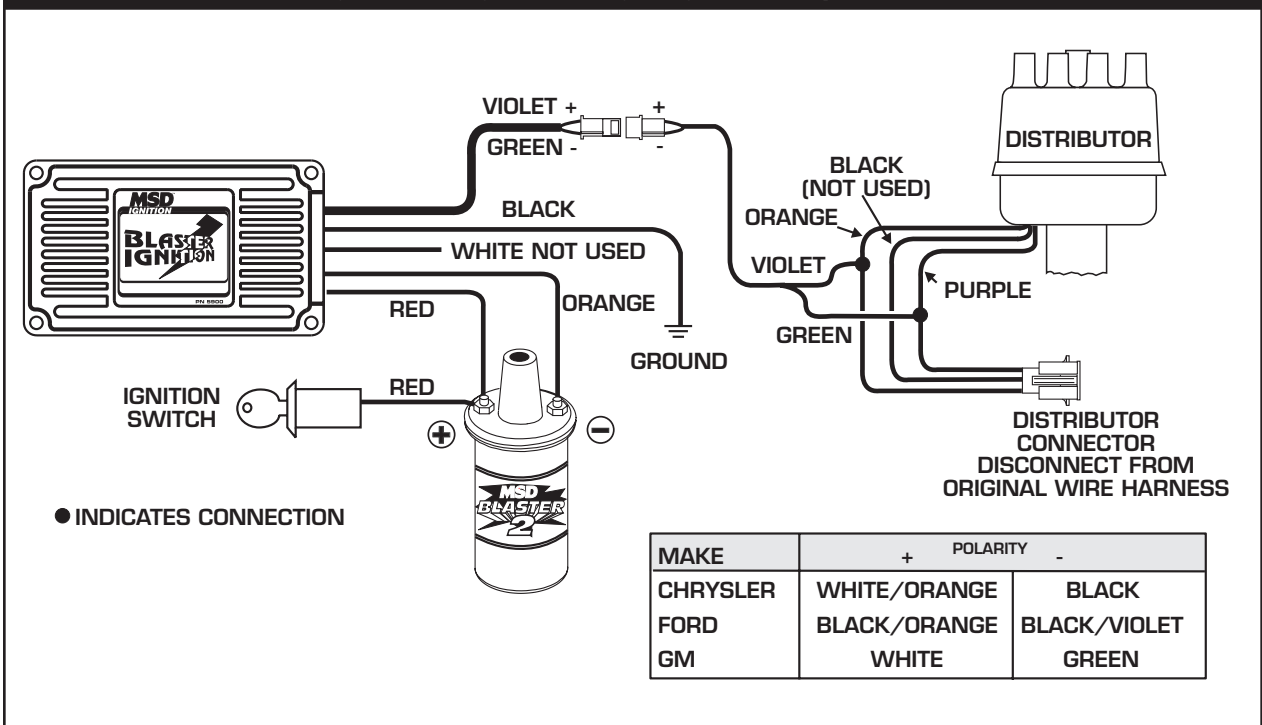

Figure 5 Wiring to a GM Dual Connector Coil.

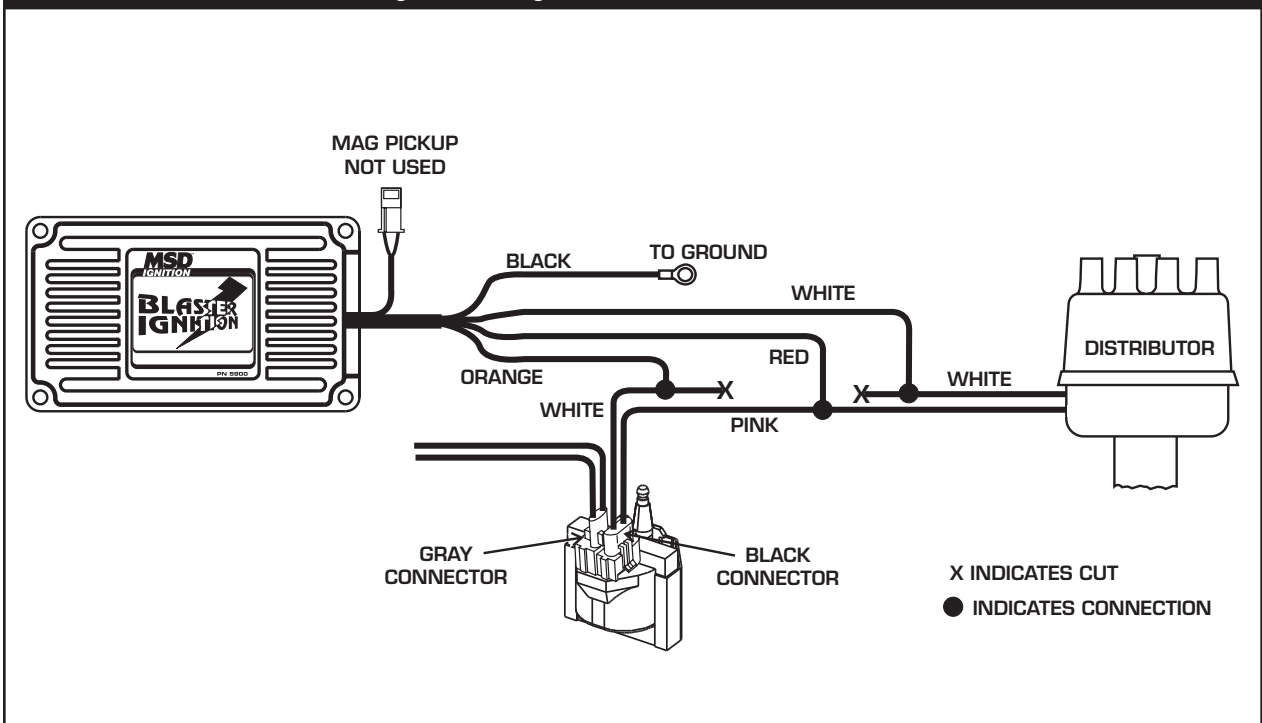

Figure 6 Wiring to a TFI Coil.

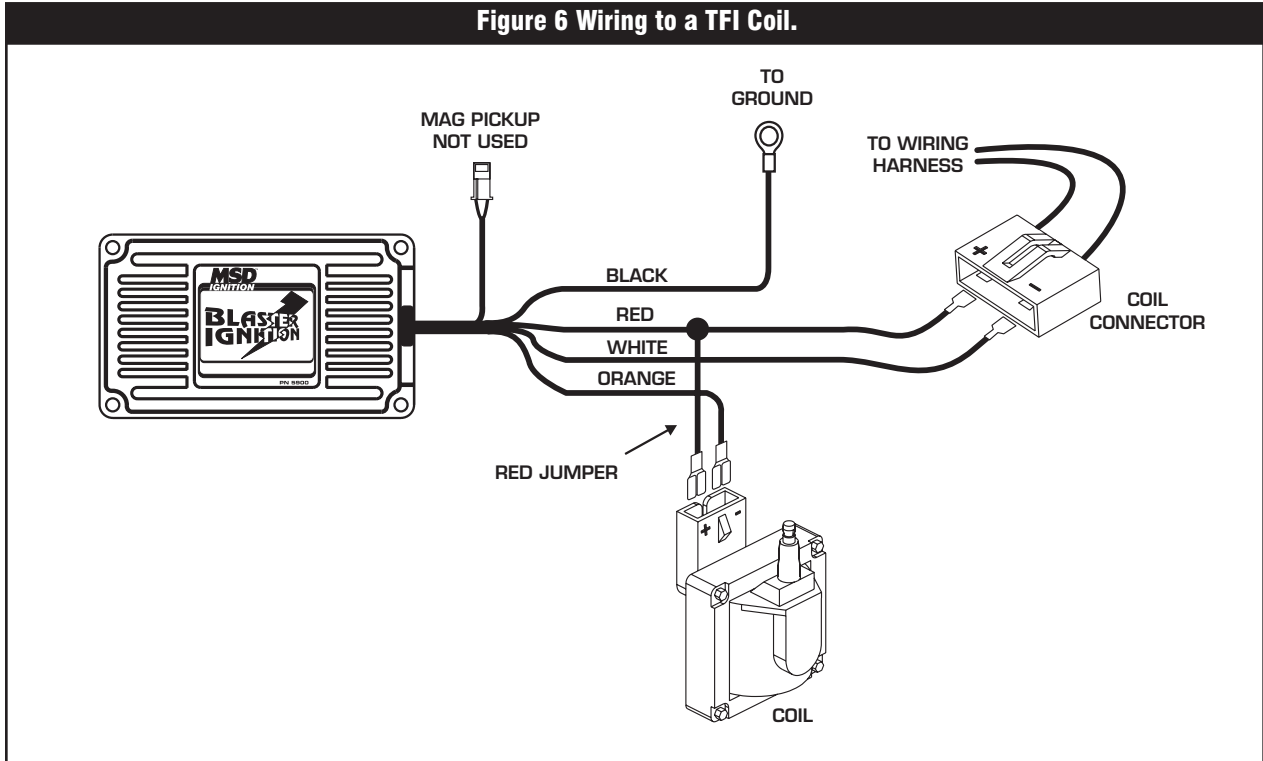
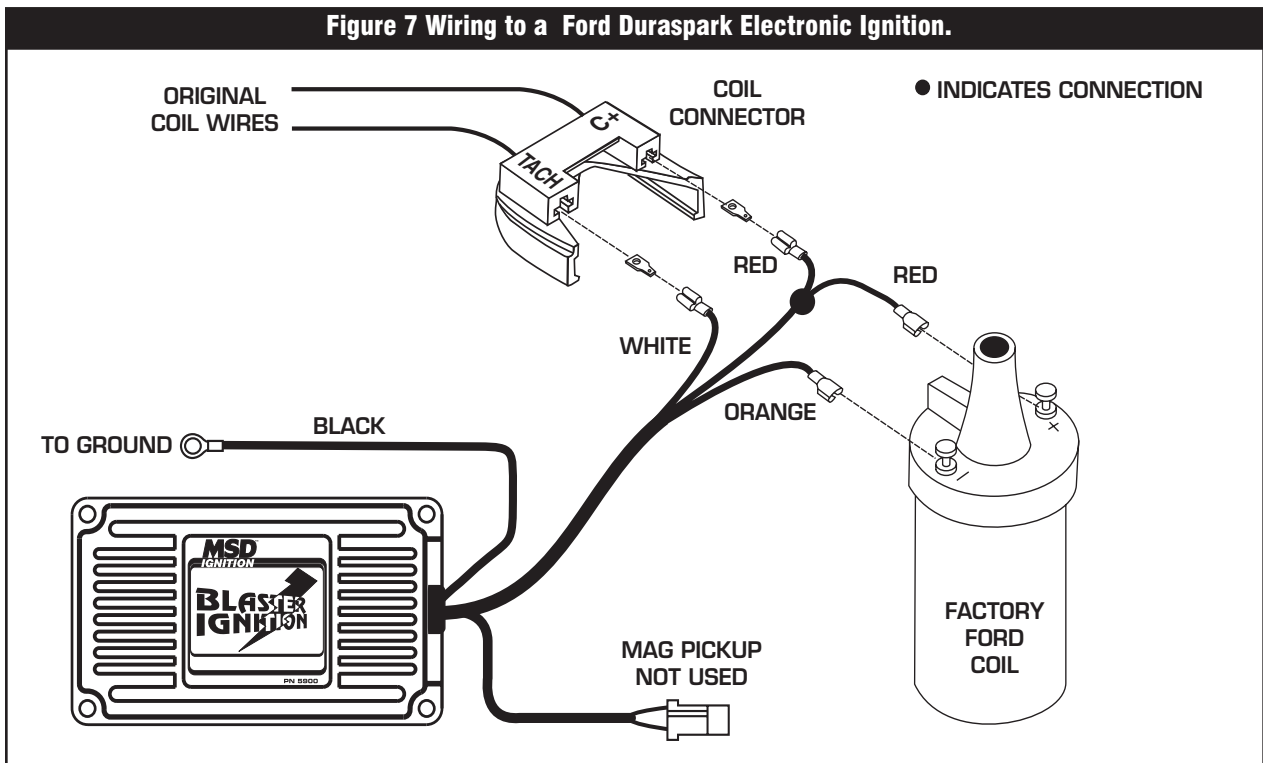

Figure 7 Wiring to a Ford Duraspark Electronic Ignition.



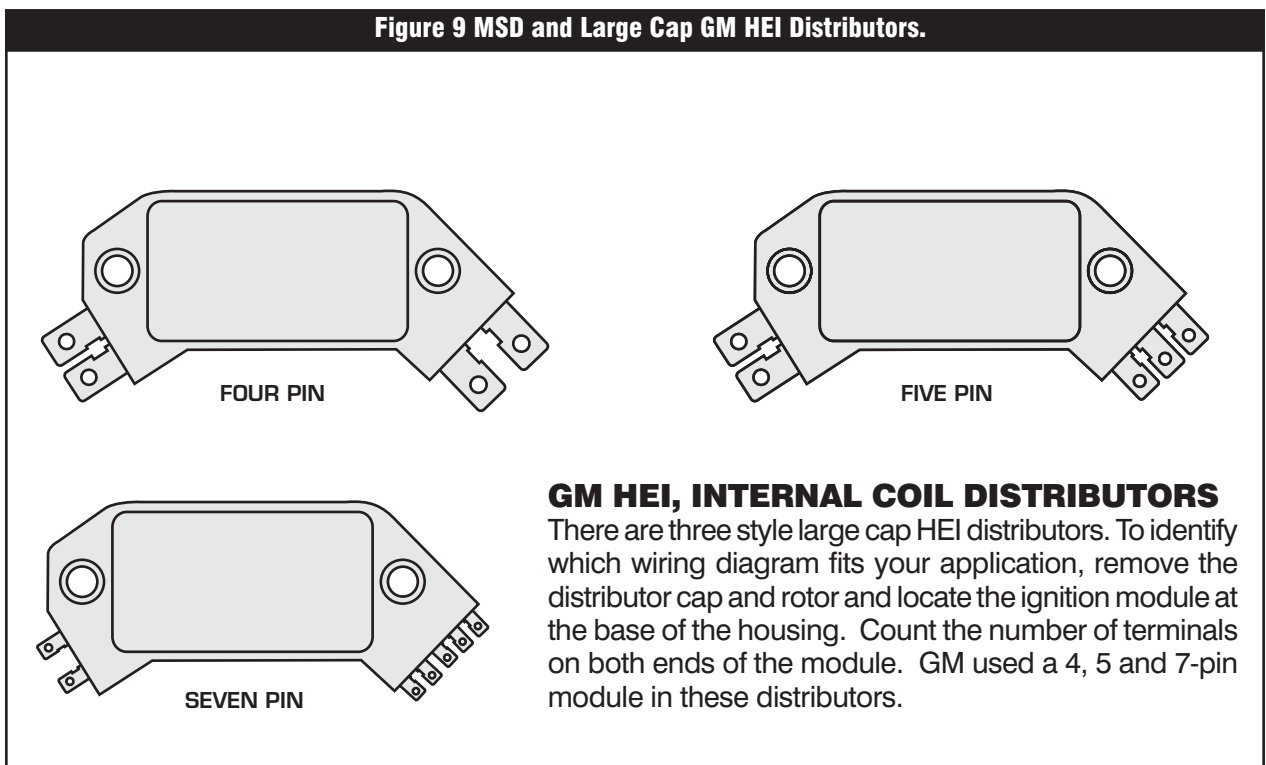
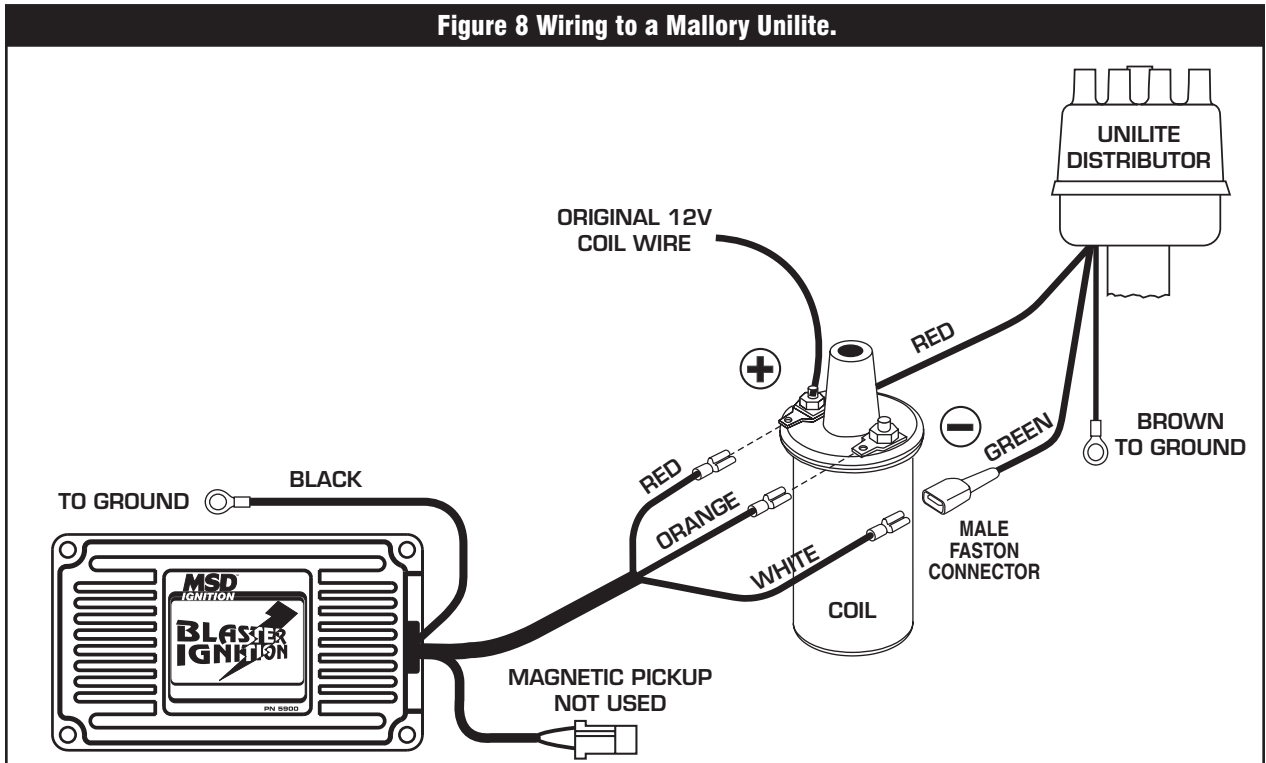

Figure 10 Wiring to a GM HEI 4-Pin Module.

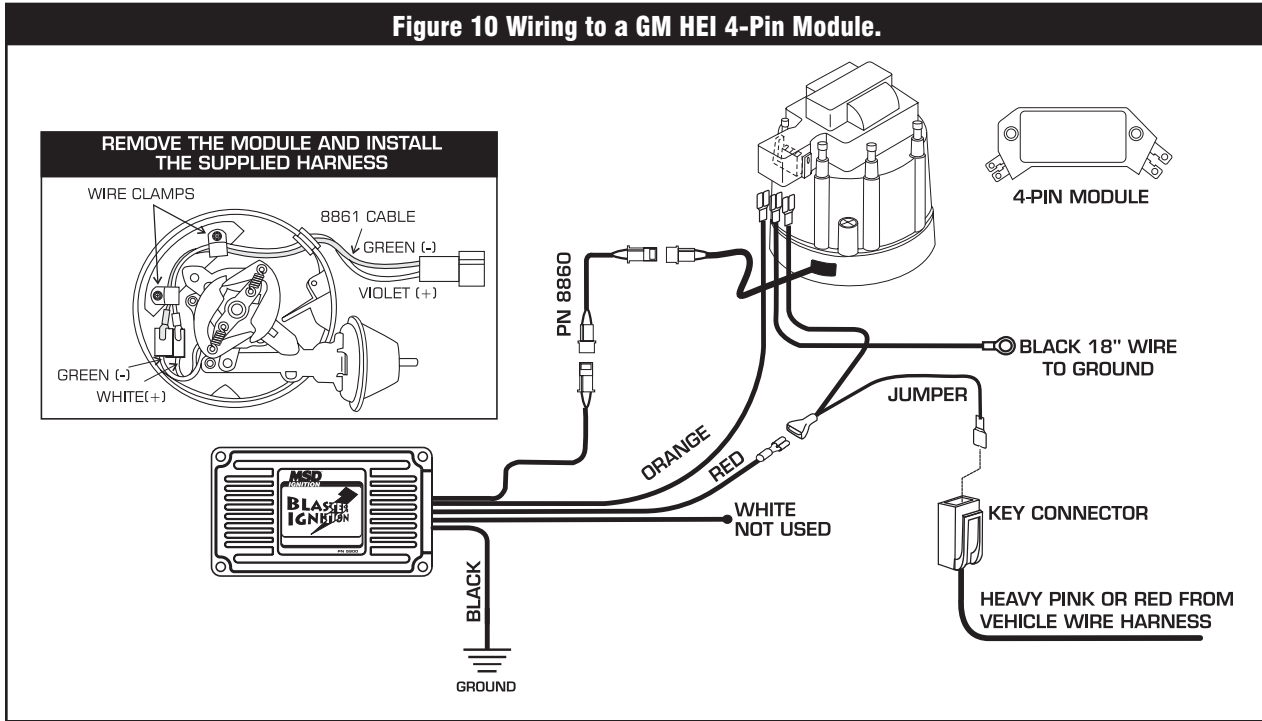

Figure 11 Wiring to a 5 or 7-Pin HEI Distributor

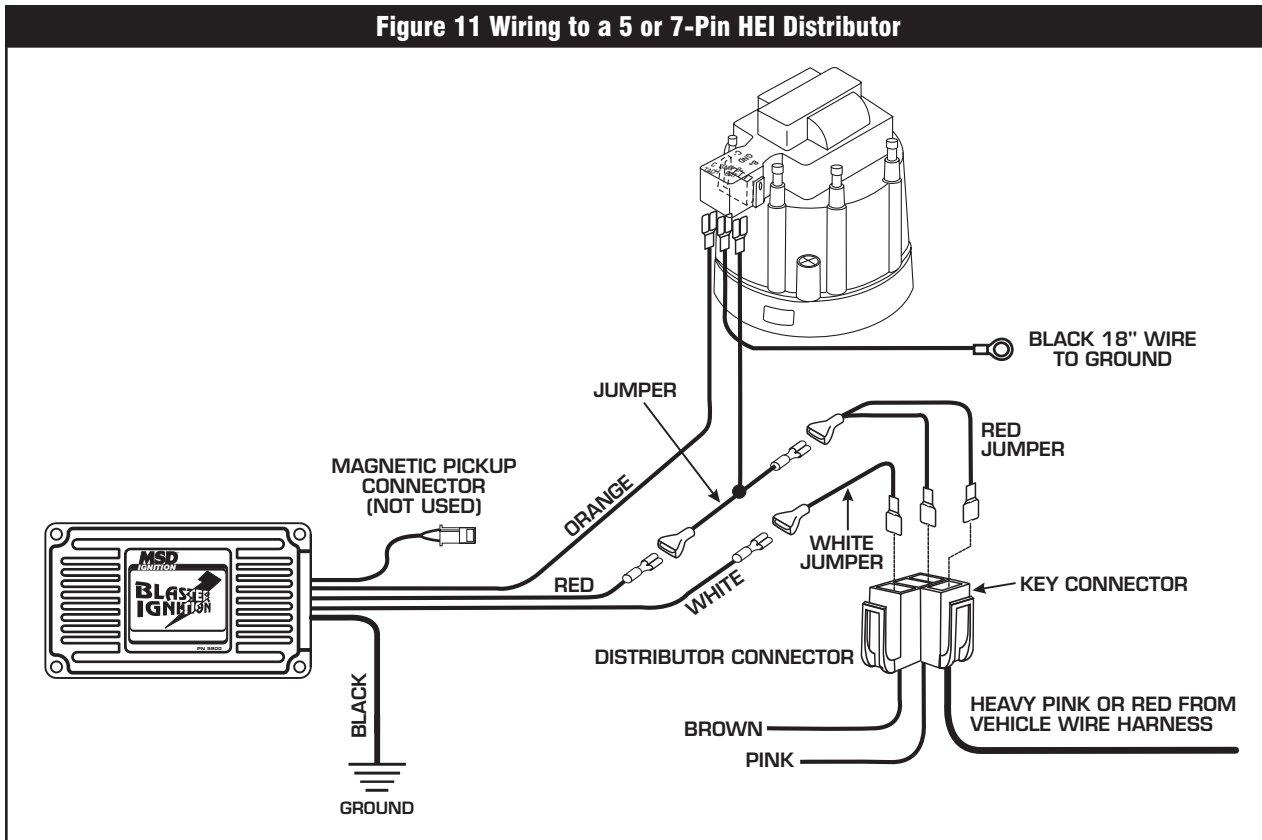
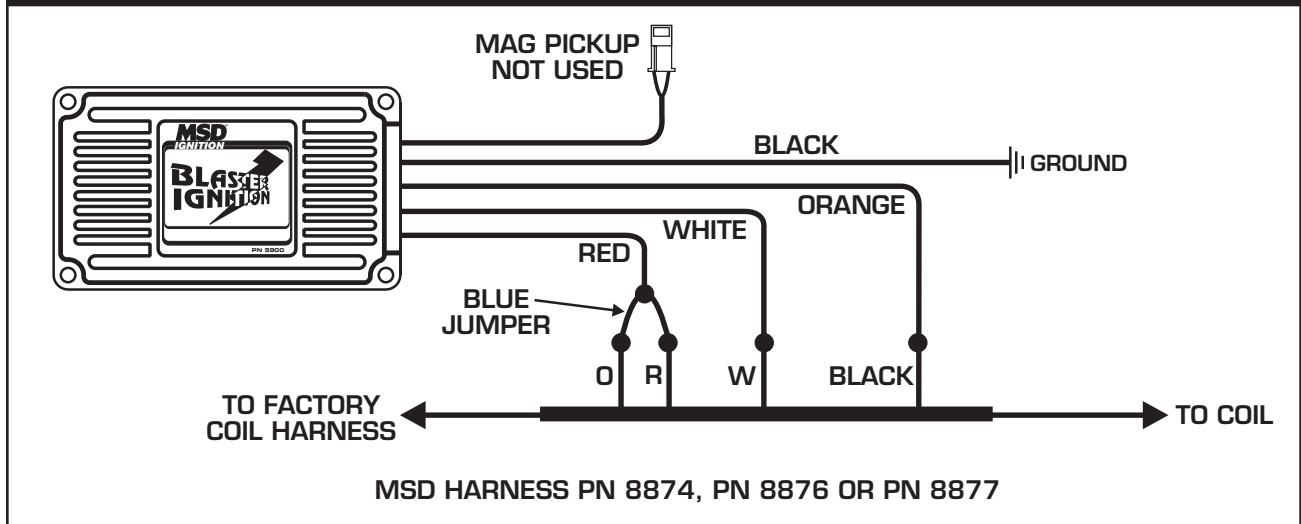

Figure 12 Wiring with an MSD-to-GM or Ford Harness.



THEFT DETERRENT

The MSD Blaster Ignition gives you the opportunity to easily install a theft deterrent kill switch.

White Wire Trigger

When using the WHITE wire to trigger the Blaster, install a switch across the magnetic pickup VIOLET wire to ground. When the connection between the VIOLET wire is grounded, the vehicle will crank but not start.

Magnetic Pickup Trigger

When using the mag pickup to trigger the Blaster, install a switch to the WHITE wire and the other side to ground. When the WHITE wire is grounded, the vehicle will crank but will not start.

Figure 13 Connecting a Theft Deterrent Switch Through the Blaster Ignition.

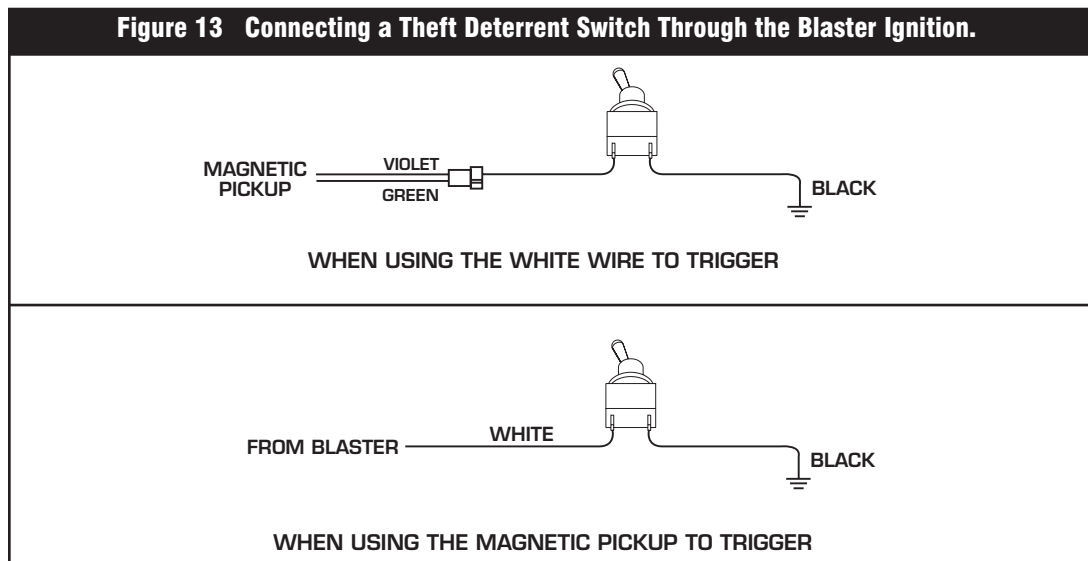

TROUBLESHOOTING

If the vehicle will not start, check over all of the wiring and connections to make sure they are tight, secure and clean. Also make sure the wires are not routed near engine heat sources, moving parts or sharp edges that may rub through. If all of the wires are in good condition, test the unit for spark.



INSTALLATION INSTRUCTIONS

WHITE WIRE TRIGGER

1. Make sure the key is OFF. Remove the coil wire from the distributor cap and set it approximately $\frac{1}{2}$ " from a good ground.
2. Disconnect the WHITE wire from the trigger source. Turn the Key On and tap the WHITE wire to ground several times. Each time the WHITE wire contacts ground a spark should jump from the coil wire to ground. If there is no spark, the Blaster or coil may be at fault. Substitute a different coil and test again. If there is now a spark, the coil was at fault. If still no spark, the Blaster unit should be sent to MSD Ignition for repair. See the Service and Warranty Section.

MAGNETIC PICKUP TRIGGER

1. Make sure the key is OFF. Remove the coil wire from the distributor cap and set it approximately $\frac{1}{2}$ " from a good ground.
2. Disconnect the magnetic pickup connector and turn the ignition to the ON position.
3. Take a short length of bare wire and momentarily short the GREEN and VIOLET terminals together. Each time the short is broken, there should be a spark from the coil wire to ground. If there is no spark, the Blaster unit or coil may be at fault. Substitute a different coil and test again. If there is now a spark, the coil was at fault. If still no spark, the Blaster unit should be sent to MSD Ignition for repair. See the Service and Warranty Section.

Service

In case of malfunction, this MSD component will be repaired free of charge according to the terms of the warranty. When returning MSD components for warranty service, **Proof of Purchase** must be supplied for verification. After the warranty period has expired, repair service is based on a minimum and maximum fee.

All returns must have a Return Material Authorization (RMA) number issued to them before being returned. To obtain an RMA number please contact MSD Customer Service at 1 (888) MSD-7859 or visit our website at www.msdisignition.com/rma to automatically obtain a number and shipping information.

When returning the unit for repair, leave all wires at the length in which you have them installed. Be sure to include a detailed account of any problems experienced, and what components and accessories are installed on the vehicle. The repaired unit will be returned as soon as possible using Ground shipping methods (ground shipping is covered by warranty). For more information, call MSD Ignition at (915) 855-7123. MSD technicians are available from 7:00 a.m. to 6:00 p.m. Monday - Friday (mountain time).

Limited Warranty

MSD IGNITION warrants this product to be free from defects in material and workmanship under its intended normal use*, when properly installed and purchased from an authorized MSD dealer, for a period of one year from the date of the original purchase. This warranty is void for any products purchased through auction websites. If found to be defective as mentioned above, it will be repaired or replaced at the option of MSD Ignition. Any item that is covered under this warranty will be returned free of charge using Ground shipping methods.

This shall constitute the sole remedy of the purchaser and the sole liability of MSD Ignition. To the extent permitted by law, the foregoing is exclusive and in lieu of all other warranties or representation whether expressed or implied, including any implied warranty of merchantability or fitness. In no event shall MSD Ignition or its suppliers be liable for special or consequential damages.

*Intended normal use means that this item is being used as was originally intended and for the original application as sold by MSD Ignition. Any modifications to this item or if it is used on an application other than what MSD Ignition markets the product, the warranty will be void. It is the sole responsibility of the customer to determine that this item will work for the application they are intending. MSD Ignition will accept no liability for custom applications.