



# INSTALLATION INSTRUCTIONS

## MSD Chevrolet V8 Pro-Billet Distributor PN 85551, PN 85561, PN 8547

**Important:** Read these Instructions before attempting the installation.

### Contents

Timing Functions  
Choosing an Advance Curve  
Setting or Locking Out the Centrifugal Advance  
Installing the Distributor  
Adjusting the Slip Collar  
Wiring the Distributor

### Parts Included:

- 1 - Pro-Billet Distributor
- 1 - Rotor, PN 8467
- 1 - Distributor Cap, PN 8433
- 1 - Gasket
- 2 - O-ring Seals
- 1 - Tube of Gear Lubricant
- 1 - Advance Kit

**Note:** An MSD Pro-Billet Distributor must be used with an MSD Ignition Control.

## TIMING FUNCTIONS

Before continuing with the installation, here are a few definitions you should be aware of:

**Initial Timing:** This is the base timing (also referred to as idle timing) of the engine before centrifugal advance begins.

**Centrifugal Advance:** The centrifugal advance mechanism is made up of weights, springs, advance cam, and an advance stop bushing. The amount and rate of advance that your distributor is capable of is determined by the centrifugal timing. If you ever wish to lock out the centrifugal advance, refer to the centrifugal advance section.

**Total Timing:** This is the total of the initial timing plus the centrifugal advance added together.  
Example:  $10^{\circ}$  Initial +  $25^{\circ}$  centrifugal =  $35^{\circ}$  Total Timing.

## CHOOSING AN ADVANCE CURVE

The function of the advance curve is to match the ignition timing to the burning rate of the fuel and speed (rpm) of the engine. Any factor that changes the burning rate of the fuel or the engine speed can cause a need for an ignition timing change. Figure 1 shows some of the factors that will affect engine timing.

FACTOR	Advance Timing For	Retard Timing For
Cylinder Pressure	Low	High
RPM	High	Low
Vacuum	High	Low
Energy of Ignition	Low	High
Fuel Octane	High	Low
Mixture (Air/Fuel)	Rich	Lean
Temperature	Cool	Hot
Combustion Chamber Shape	Open	Compact
Spark Plug Location	Offset	Center
Combustion Turbulence	Low	High
Load	Light	Heavy

**Figure 1 Ignition Timing Factors.**

As you can see from the chart, most factors will change throughout the range of the engine operation. The timing mechanism of the distributor must make timing changes based on these factors.

**Example:** A Chevy V8 has 11:1 compression, a high energy ignition and turns 5,500 rpm. With the specifications given, you will have to retard the timing for the high compression, low rpm and high energy ignition. By comparing the engine's specifications against the chart, a usable timing guideline can be found. Engines with a combination of items from both columns will require a timing that is set in the mid range.

Obviously a full technical explanation of correct ignition timing would be very complicated. The best way to arrive at a suitable ignition curve for your engine is to use the Ignition Timing Factors Chart as a guide and compare it to the Advance Graphs in Figure 2 until a suitable curve is found. When selecting your advance curve, use detonation (engine ping) as an indicator of too much advance, and a decrease in power as an indicator of too little advance.

### TIPS ON SELECTING AN ADVANCE CURVE

- Use as much initial advance as possible without encountering excessive starter load or engine kick-back.
- Start the centrifugal advance just above the idle rpm.
- The starting point of the centrifugal advance curve is controlled by the installed length and tension of the spring.
- How quickly the centrifugal advance (slope) comes in is controlled by the spring stiffness. The stiffer the spring, the slower the advance curve.
- The amount of advance is controlled by the advance bushing. The bigger the bushing, the smaller the amount of advance.

## CENTRIFUGAL ADVANCE CURVE

The centrifugal advance mechanism is made up of weights, springs, an advance cam and the advance stop bushing. The distributor can be used in a wide selection of applications by changing only the springs and the advance stop bushing. There is no need to change the weights or advance cam.

### SELECTING THE ADVANCE SPRINGS

The rate, or how quick the advance comes in is determined by the type of springs which are installed on the distributor. The MSD distributors are equipped with two Heavy Silver springs installed. These will give you the slowest advance curve possible. The parts kit contains two additional sets of springs which can be used to match the advance curve to your particular application. Refer to the Spring Combination Chart (Figure 3) for combinations that can be achieved.

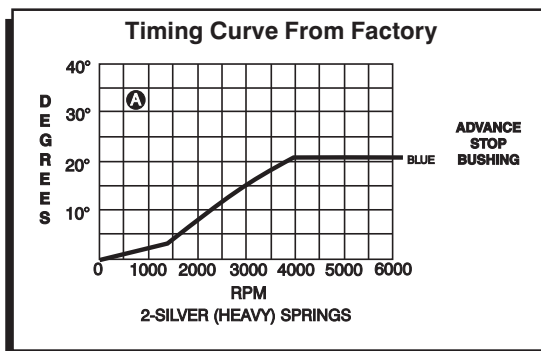

Figure 2 The Factory Equipped Curve.

SPRING COMBINATION	RATE OF ADVANCE	FIGURE 3 (Page 4)
2- Heavy Silver	SLOWEST	A
1- Heavy Silver 1- Light Blue		B
1-Heavy Silver 1-Light Silver		C
2- Light Blue		D
1- Light Silver 1- Light Blue		E
2- Light Silver		F
		FASTEST

Figure 3 Spring Combination Chart.

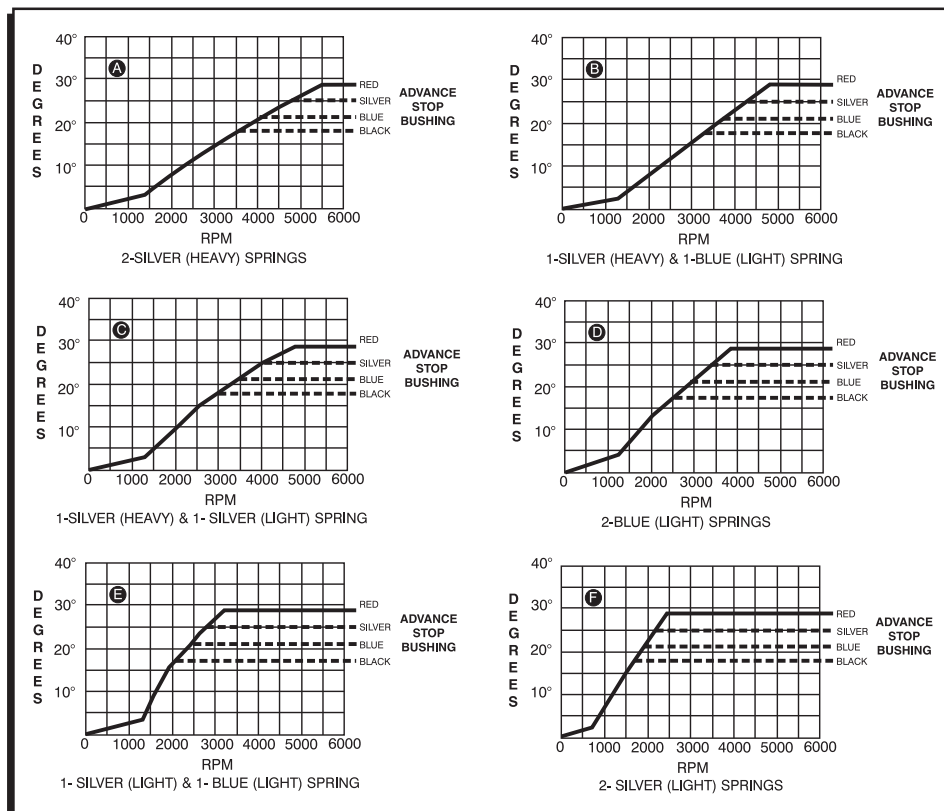

Figure 4 Advance Curves.

## INSTALLING THE ADVANCE SPRINGS

1. Remove the distributor cap and rotor.
2. Using long needle nose pliers, remove the springs from the spring posts.
3. Install the new springs using the pliers and install the rotor and cap.

## SELECTING THE ADVANCE STOP BUSHING

Three different advance stop bushings are supplied in the distributor kit. The distributor comes with a Blue (21°) bushing already installed. If a different amount of centrifugal advance is desired, follow the next procedure to change the bushings. The chart in Figure 5 gives the size and approximate degrees for the corresponding bushings.

BUSHING SIZE	APPROXIMATE CRANKSHAFT DEGREES
Red-Smallest	28
Silver	25
Blue	21
Black-Largest	18

Figure 5 Advance Stop Bushing Chart.

## CHANGING THE ADVANCE STOP BUSHING

1. Remove the distributor cap and rotor.
2. Remove the locknut and washer on the bottom of the advance assembly (Figure 6).
3. Remove the bushing and install the new one. Install the washer and locknut.

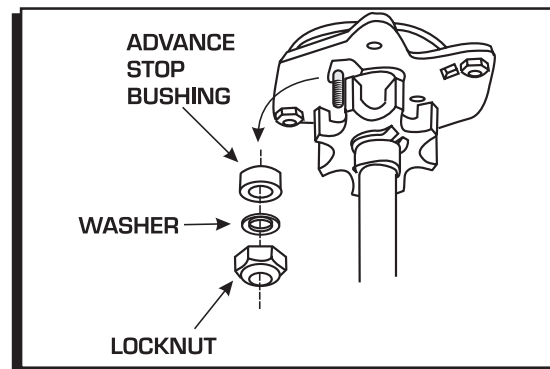

Figure 6 Changing the Advance Stop Bushing.

## LOCKING OUT THE CENTRIFUGAL ADVANCE

1. Remove the advance springs, weights and the advance stop bushing from the advance assembly.
2. Remove the roll-pin from the drive gear and remove the gear from the shaft.
3. Slide the shaft two inches out of the housing.
4. Rotate the shaft 180° and insert the advance stop bushing pin into the small hole on the advance plate (Figure 7).
5. Install the locknut and washer to the advance stop bushing pin.
6. Install the drive gear and roll-pin.

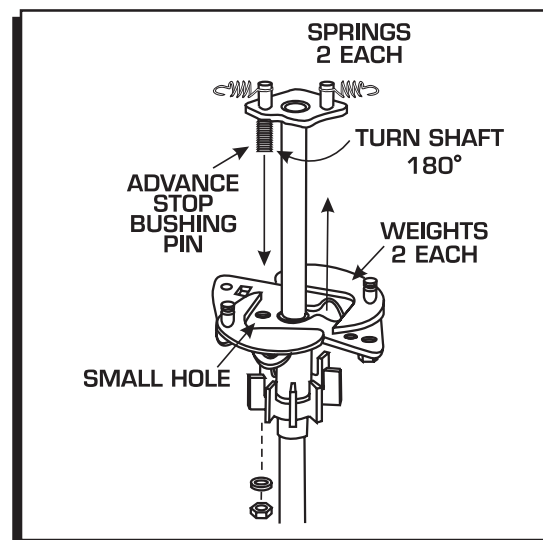

Figure 7 Locking Out the Advance.

## INSTALLING THE DISTRIBUTOR

1. Remove the existing distributor cap without disconnecting any of the spark plug wires.
2. With the cap off, crank the engine until the rotor is aimed at a fixed point on the engine or firewall. Note this position by making a mark (Figure 8).
3. Place the distributor cap back on and note which plug wire the rotor is pointing to. **MARK THE SPARK PLUG WIRES** and remove the distributor cap.
4. Disconnect the wiring from the distributor.
5. Loosen the distributor hold down clamp and slide the clamp out of the way.

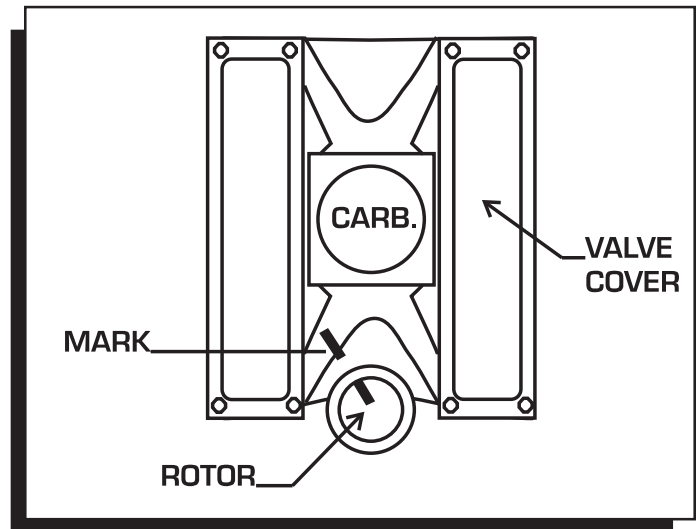

Figure 8 Marking the Rotor Location.

6. Lift the distributor out of the engine. Note that the rotor rotates as you lift the distributor out. This is due to the helical cut gear and should be taken into consideration when installing the new distributor.

**Note:** If equipped, set the adjustment of the slip collar shown in the procedure on page 6 before installing the distributor.

7. With the slip collar adjustment set, install the gasket and O-rings (if necessary). The O-rings can only be used if the block has been modified as shown in figure 9.
8. Apply a liberal amount of the supplied lubricant to the distributor gear.
9. Install the distributor making sure that the rotor comes to rest pointing at the fixed mark. If the distributor will not fully seat with the rotor pointing to the marked position, you may need to rotate the oil pump shaft until the rotor lines up and the distributor fully seats.
10. Position and tighten the hold down clamp onto the distributor.
11. Install the distributor cap and spark plug wires one at a time to ensure correct location.

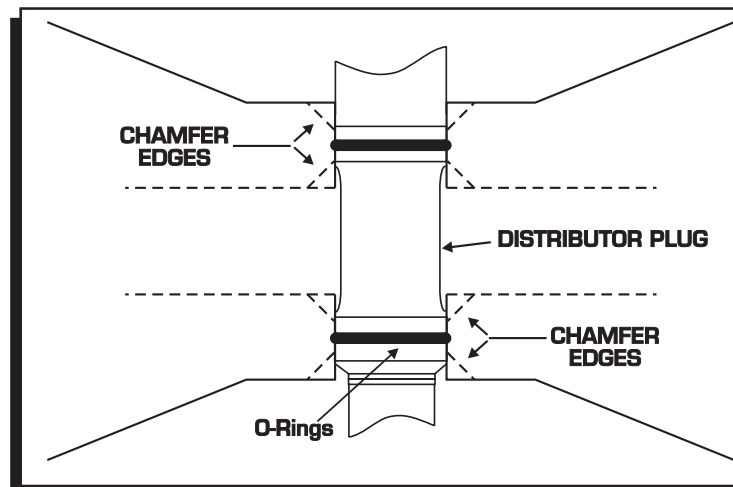

Figure 9 Modified Block for use with O-Rings.

## **ADJUSTING THE SLIP COLLAR**

Before installing the Pro-Billet Distributor, the slip collar adjustment must be set. MSD offers a special tool, the 3-In-1 Distributor Set Up Tool, PN 8599, to make these adjustments accurately. If the tool is not available, follow this procedure.

1. Loosen the slip collar and insert the distributor into the engine until it bottoms out against the oil pump drive.
2. After it bottoms out, raise the distributor 0.010" - 0.030" then slide the slip collar down into position and tighten it.

### **CHECKING GEAR MESH**

It is recommended to check for proper gear mesh between the cam gear and distributor gear. To do this, coat the distributor gear with moly grease and install the distributor. Next, crank the engine over several times. Before pulling the distributor out, make sure the rotor is in the position that lines up with the original removal mark. Then pull the distributor out and inspect the gear pattern shown on the grease. The proper mesh will leave an even pattern in the middle of the gear. Adjust the slip collar to obtain the correct mesh.

### **CHECKING THE OIL PUMP TO DISTRIBUTOR SHAFT OVERLAP**

The proper overlap between the distributor shaft and the oil pump shaft is very important. The tongue of the distributor shaft should fit into the groove of the oil pump shaft by at least 1/4".

#### **TO CHECK THIS:**

1. Measure the distance between the base of the slip collar to the tip of the distributor shaft (Figure 10).
2. Using a straight edge, measure the distance from the intake manifold distributor flange to bottom groove on the oil pump shaft (Figure 10).
3. Take the two measurements and subtract them. The difference is the overlap. If there is not enough clearance or too much clearance, a different oil pump shaft is required.

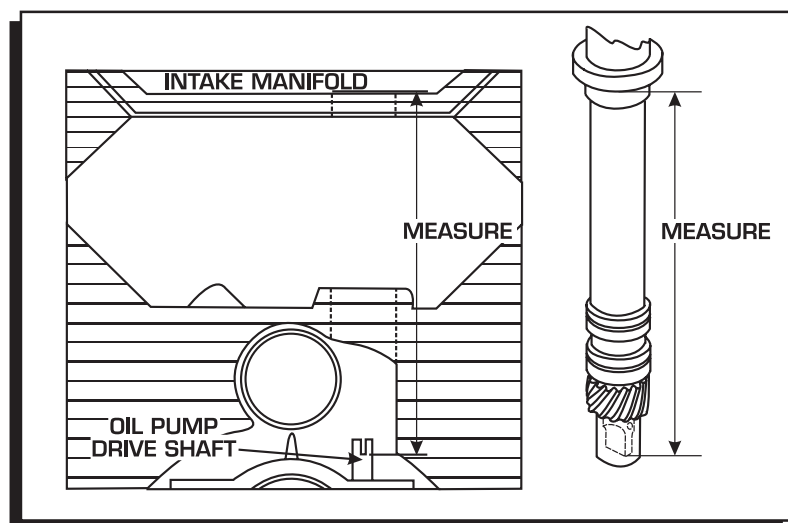

**Figure 10 Measuring Oil Pump Shaft Overlap.**

**WIRING THE DISTRIBUTOR**

The MSD Pro-Billet Distributor must be used with an MSD Ignition Control. Figure 11 shows the wiring for the MSD distributor with an MSD 6, 7, 8 or 10 Series Ignition Control.

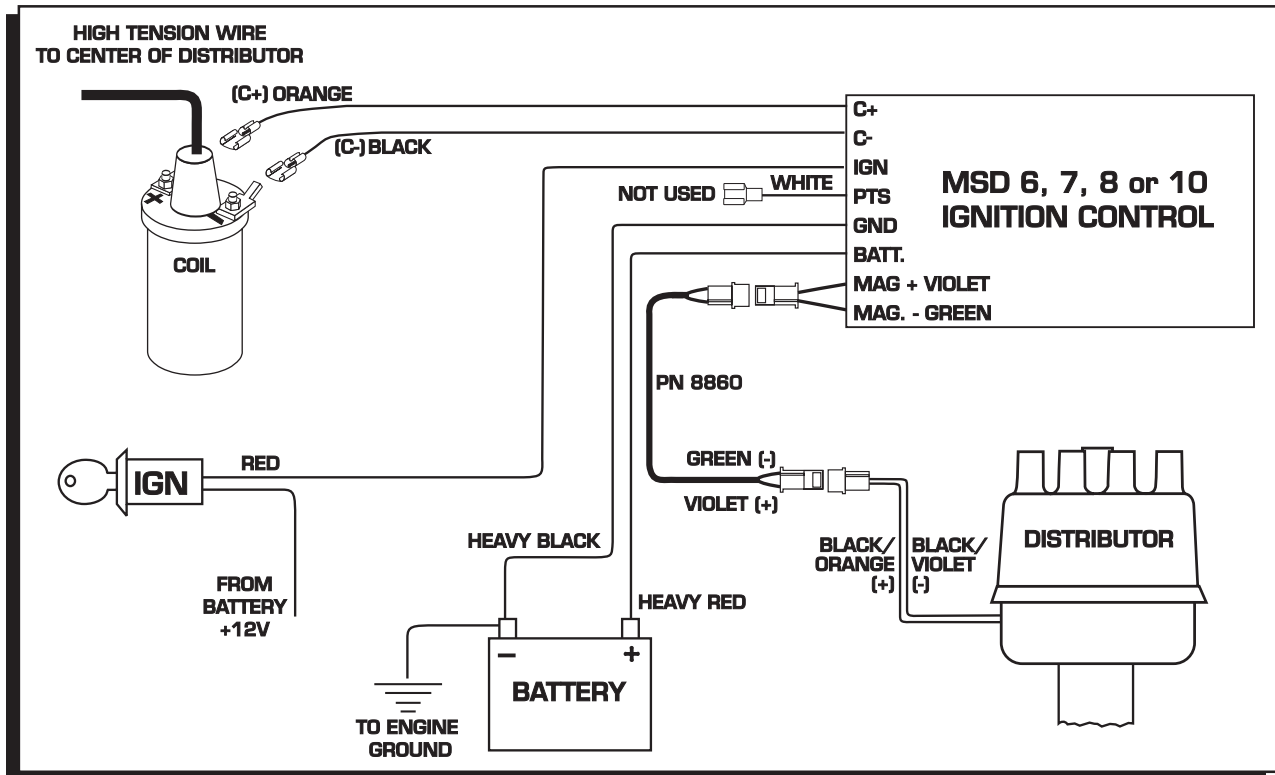

Figure 11 Wiring the Distributor.



# INSTALLATION INSTRUCTIONS

## Notes

---

---

---

---

---

---

---

---

---

---

---

---

---

---

---

---

---

---

---

---

---

---

---

---

---

### Service

In case of malfunction, this MSD component will be repaired free of charge according to the terms of the warranty. When returning MSD components for service, Proof of Purchase must be supplied for warranty verification. After the warranty period has expired, repair service is charged based on a minimum and maximum charge.

Send the unit prepaid with proof of purchase to the attention of: **Customer Service Department, Autotronic Controls Corporation, 12120 Esther Lama, Suite 114, El Paso, Texas 79936.**

When returning the unit for repair, leave all wires at the length in which you have them installed. Be sure to include a detailed account of any problems experienced, and what components and accessories are installed on the vehicle.

The repaired unit will be returned as soon as possible after receipt, COD for any charges. (Ground shipping is covered by warranty). All units are returned regular UPS unless otherwise noted. For more information, call the MSD Customer Service Line (915) 855-7123. MSD technicians are available from 8:00 a.m. to 5:00 p.m. Monday - Friday (mountain time).

### Limited Warranty

Autotronic Controls Corporation warrants MSD Ignition products to be free from defects in material and workmanship under normal use and if properly installed for a period of one year from date of purchase. If found to be defective as mentioned above, it will be replaced or repaired if returned prepaid along with proof of date of purchase. This shall constitute the sole remedy of the purchaser and the sole liability of Autotronic Controls Corporation. To the extent permitted by law, the foregoing is exclusive and in lieu of all other warranties or representations whether expressed or implied, including any implied warranty of merchantability or fitness. In no event shall Autotronic Controls Corporation be liable for special or consequential damages.