

MSD[®] IGNITION

INSTALLATION INSTRUCTIONS

Flying Magnet Crank Trigger Kit Ford Big Block Engines: 351 C/M, 400, 429, 460 PN 8644

Important: Read the instructions before attempting the installation.

Parts Included:

1 - Trigger Wheel	2 - Bolts, 5/16" - 24 x 1 1/4"
1 - Pickup Holder Assembly	2 - Bolts, 5/16"- 18 x 3 1/4"
1 - Trigger Wheel Spacer	2 - 5/16" Washers
1 - Non Magnetic Pickup Assembly	3 - Bolts, 3/8"- 16 x 1 1/4"
1 - Pickup Base	3 - 3/8" Washers
1 - Locknut	2 - Thin Spacer Washers
3 - Spacers	Tech Bulletin #104

Note: On some vehicles the MSD Crank Trigger Kit may require slight modifications to accommodate special engine plates, pulley systems, etc.

INSTALLING THE PICKUP AND BRACKET

1. Mount the pickup holder onto the bracket using the two fine thread bolts (Figure 1). The pickup base will only install one way, do not try to force the bolts in, and hand tighten the bolts.
2. Install the bracket onto the engine. The bracket is designed to be used on either side of the balancer. Be sure to use the correct length bolts and shims in the proper location.
3. Install the pickup and locknut into the holder. Do not tighten the locknut at this time.

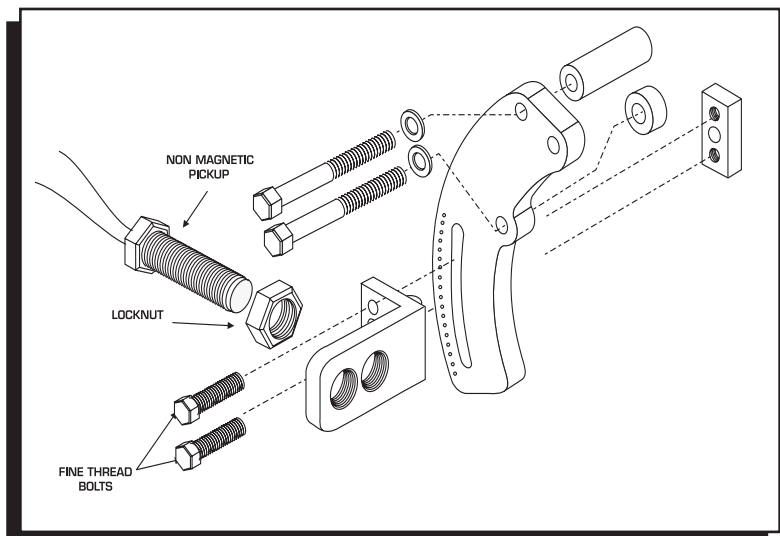
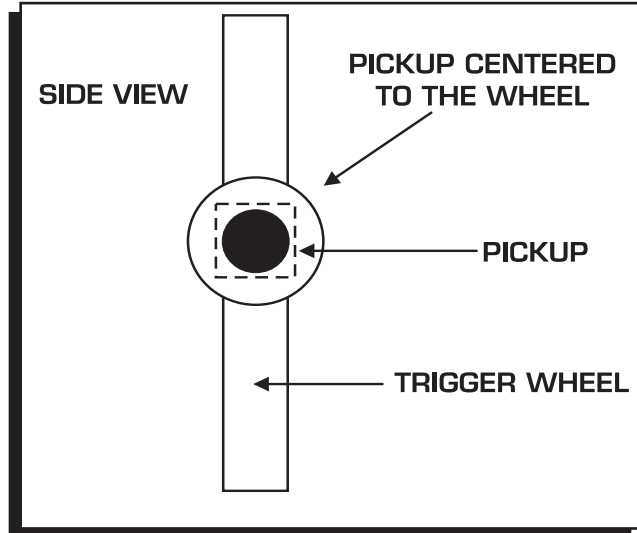

Figure 1 Pickup Bracket Assembly.

INSTALLING THE TRIGGER WHEEL

1. Position the No. 1 cylinder under compression at the desired total timing. Install the trigger wheel centering ring onto the harmonic balancer of the engine.
2. Position the trigger wheel onto the harmonic balancer and centering ring so one of the four magnets lines up with the center of the non magnetic pickup. Make sure the wheel is mounted so it rotates in the direction of the arrow on the wheel. If necessary, slide the pickup in its mount until it properly lines up with the trigger wheel magnet.
3. Check and make sure the wheel is positioned correctly with the pickup and torque the trigger wheel bolts to 25 - 30 lb-ft. The pickup should be centered to the edge of the trigger wheel (Figure 2). If not, it may be necessary to add or delete shims to the pickup bracket to achieve the proper position.

**Figure 2 Pickup Centered on the Trigger Wheel.****Service**

In case of malfunction, this MSD component will be repaired free of charge according to the terms of the warranty. When returning MSD components for warranty service, **Proof of Purchase** must be supplied for verification. After the warranty period has expired, repair service is based on a minimum and maximum fee.

All returns must have a Return Material Authorization (RMA) number issued to them before being returned. To obtain an RMA number please contact MSD Customer Service at 1 (888) MSD-7859 or visit our website at www.msdisignition.com/rma to automatically obtain a number and shipping information.

When returning the unit for repair, leave all wires at the length in which you have them installed. Be sure to include a detailed account of any problems experienced, and what components and accessories are installed on the vehicle. The repaired unit will be returned as soon as possible using Ground shipping methods (ground shipping is covered by warranty). For more information, call MSD Ignition at (915) 855-7123. MSD technicians are available from 7:00 a.m. to 6:00 p.m. Monday - Friday (mountain time).

Limited Warranty

MSD IGNITION warrants this product to be free from defects in material and workmanship under its intended normal use*, when properly installed and purchased from an authorized MSD dealer, for a period of one year from the date of the original purchase. This warranty is void for any products purchased through auction websites. If found to be defective as mentioned above, it will be repaired or replaced at the option of MSD Ignition. Any item that is covered under this warranty will be returned free of charge using Ground shipping methods.

This shall constitute the sole remedy of the purchaser and the sole liability of MSD Ignition. To the extent permitted by law, the foregoing is exclusive and in lieu of all other warranties or representation whether expressed or implied, including any implied warranty of merchantability or fitness. In no event shall MSD Ignition or its suppliers be liable for special or consequential damages.

*Intended normal use means that this item is being used as was originally intended and for the original application as sold by MSD Ignition. Any modifications to this item or if it is used on an application other than what MSD Ignition markets the product, the warranty will be void. It is the sole responsibility of the customer to determine that this item will work for the application they are intending. MSD Ignition will accept no liability for custom applications.