



INSTALLATION INSTRUCTIONS

MSD-to-BUICK COIL PACK INTERFACE 1986-1987 V6 Engines PN 8878

- | | |
|----------------------|---------------------|
| 1 - Interface Module | 2 - Gaskets |
| 6 - Screws | 1 - Adapter Harness |

The MSD Interface Module provides you with a splice-free installation of an MSD-DIS-4 Ignition Control onto your '86-'87 Buick T-Type or Grand National.

1. Remove the six screws holding the Coil assembly to the ignition module. Note the cylinder numbers on the coil pack.

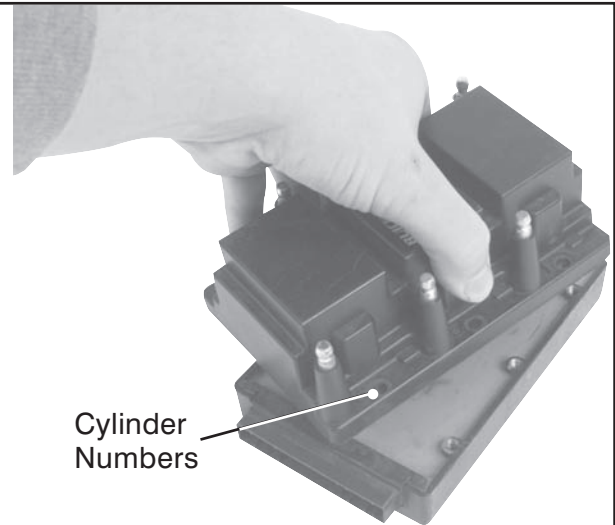

Figure 1 Disassembling the Coil/Module.

2. Slowly lift the coil assembly to the side of the ignition module. Note that there are six wires connected to the coil pack. There will be three Blue wires on one side with a Green/Black, Yellow/Black and Lt. Blue/Black on the other side. Mark their positions to correspond with the number of each coil terminal then disconnect all of them.

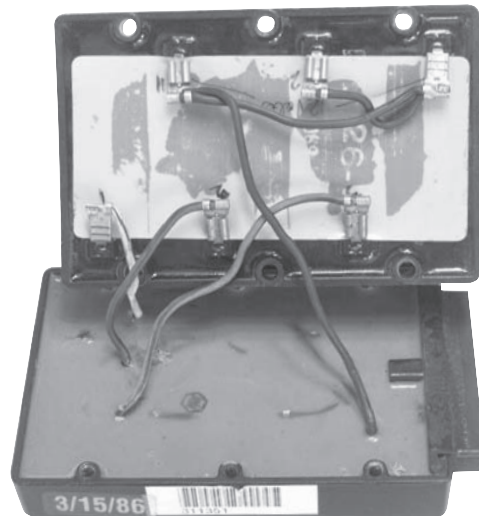
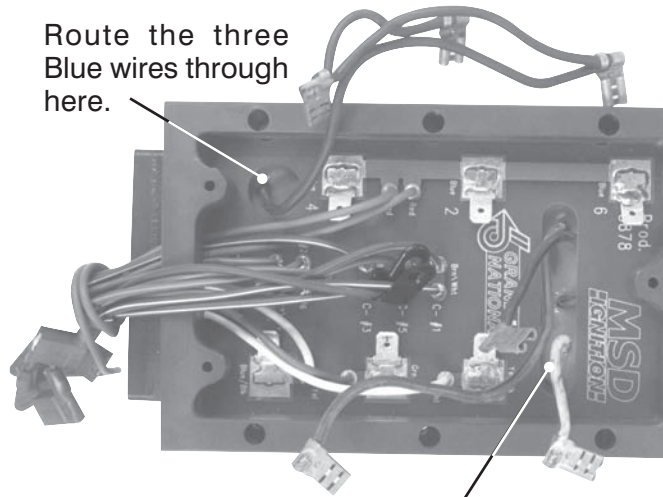

Figure 2 Disconnecting the Wiring.

3. Position the MSD Interface over the ignition module with the wiring harness on the same side as the factory harness. Note the two holes in the circuit board to route the factory module's wires through.



Route the wires with a black tracer through here.

Figure 3 Installing the Interface Assembly.

4. The three Blue wires connect to the terminals marked "Blue 6, 4 and 2" for each cylinder number. The other terminals inside the interface are marked for the corresponding wire colors.

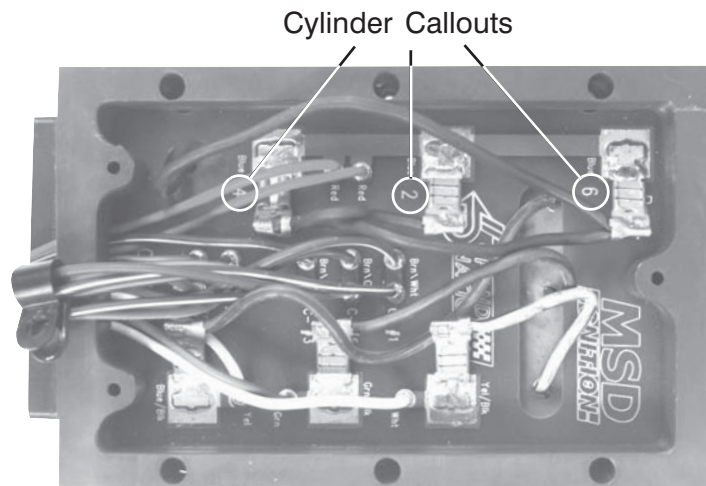

Figure 4 Connecting the Module Wiring.

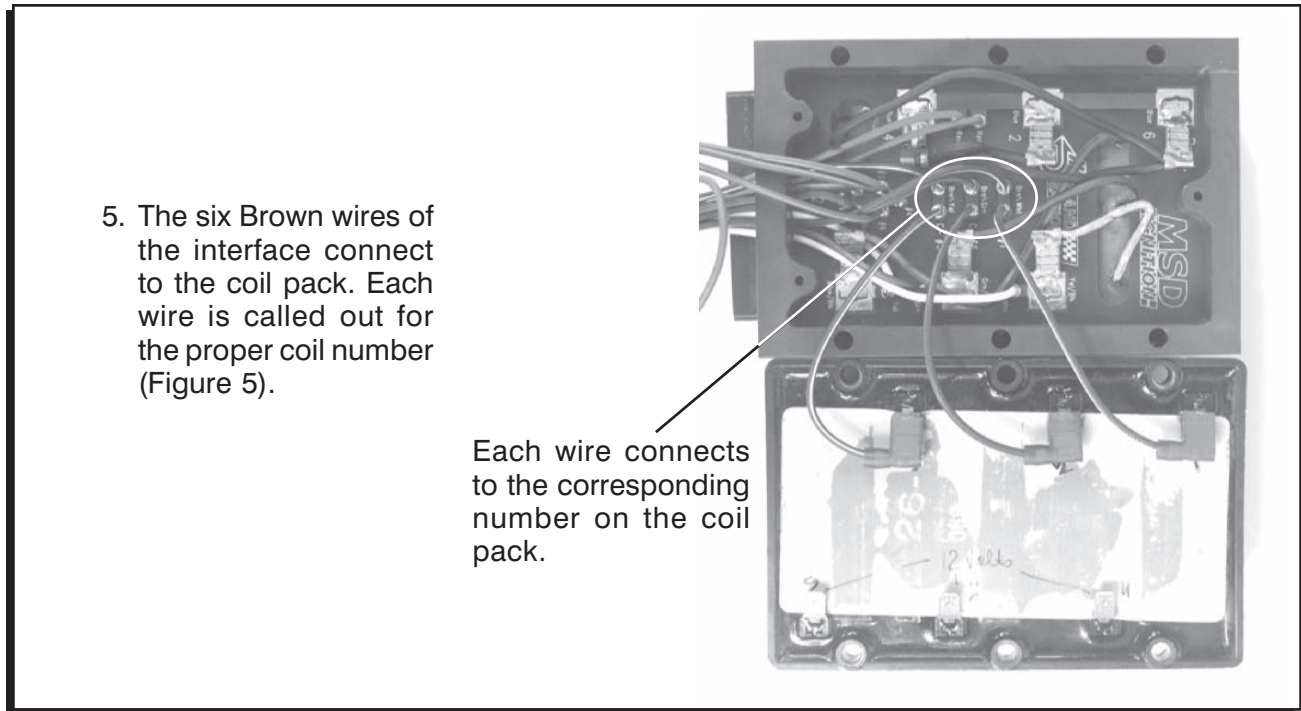

Figure 5 Connecting the Coil Wiring.

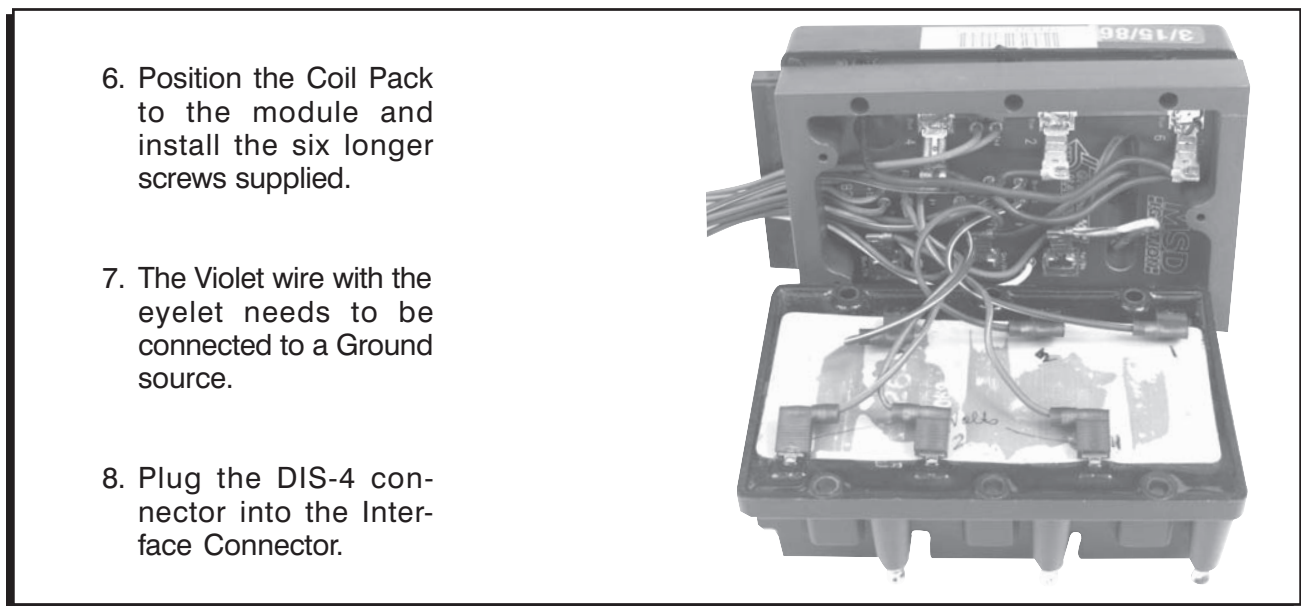
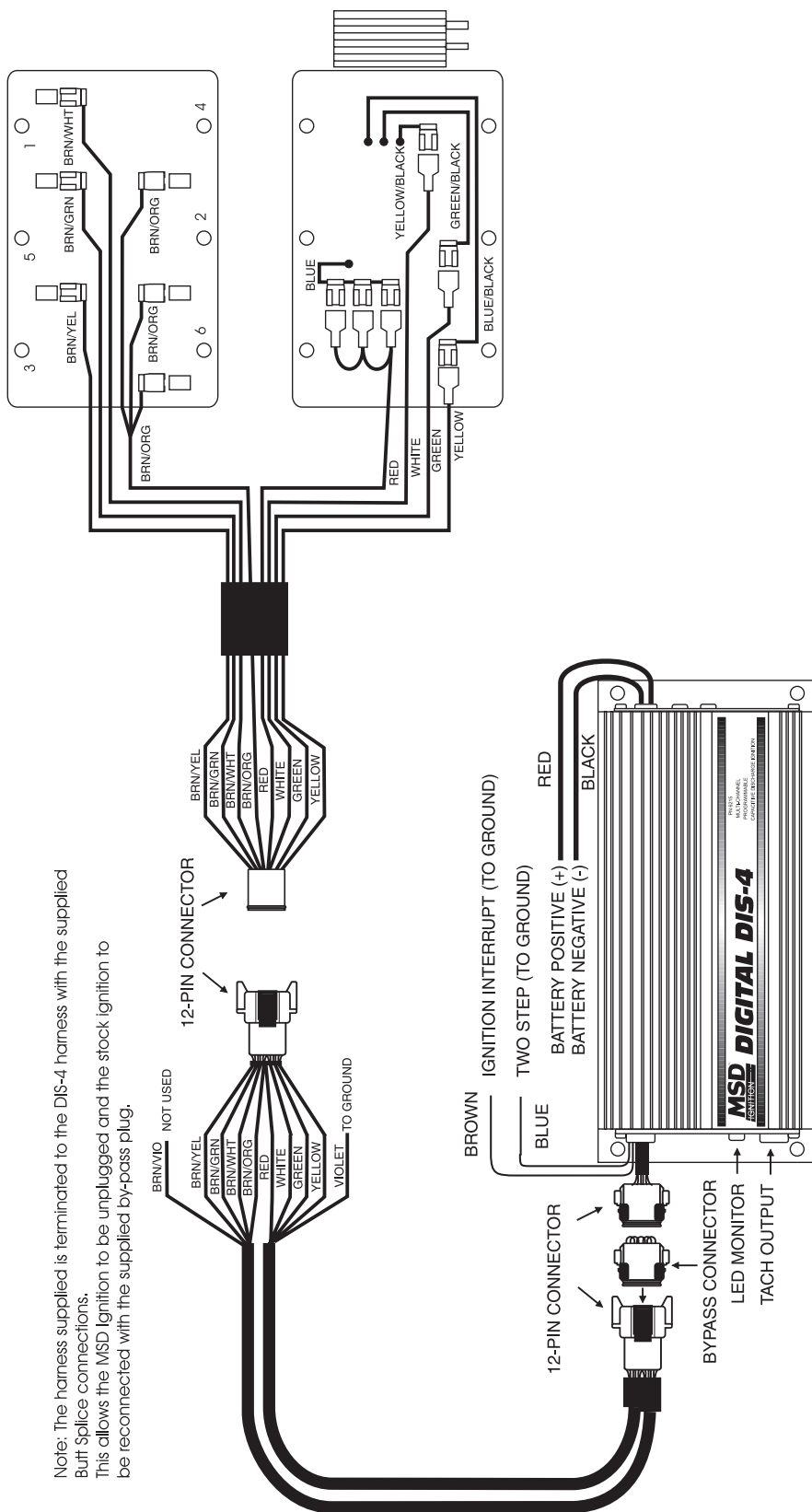

Figure 6 Connecting the Coil Wiring.



Note: The harness supplied is terminated to the DIS-4 harness with the supplied butt splice connections. This allows the MSD Ignition to be unplugged and the stock ignition to be reconnected with the supplied by-pass plug.

Figure 7 Wiring a DIS-4 with PN 8878.