

# MSD IGNITION INSTALLATION INSTRUCTIONS

## Dual Ignition Coil Ignitor PN 6302

### Parts Included:

- 1 - Dual Ignition Coil Ignitor
- 1 - Parts Bag

The MSD Dual Ignition Coil Ignitor allows for the installation of an MSD DIS-2 Series Ignition Control and MSD Coils on vehicles with factory transistorized/driver style coils. It achieves this by inverting the logic signal from the ECU and creating a high current output to drive an inductive coil, or points input of an MSD Ignition Box.

**Note:** There are a number of different applications that can use the PN 6302. These instructions illustrate an installation on a 4-cylinder with 2 wasted spark coils. It is recommended to have the wiring schematic of your vehicle prior to installation.

### MOUNTING

The Dual Ignition Coil Ignitor is designed to be mounted under the hood. The circuits are potted in polyurethane for water resistance and vibration protection. Position the unit away from excessive heat sources and mark the location of the three mounting holes. Use a 5/32" bit to drill the holes and secure the unit with the supplied screws.

### WIRING

The Dual Ignition Coil Ignitor comes with both male and female bullet terminals installed on the harness. These terminals are designed to plug directly into the harness of an MSD DIS-2 Ignition, color-to-color. The ring lugs supplied in the parts bag install on the black wires and are to be connected to a good chassis ground.

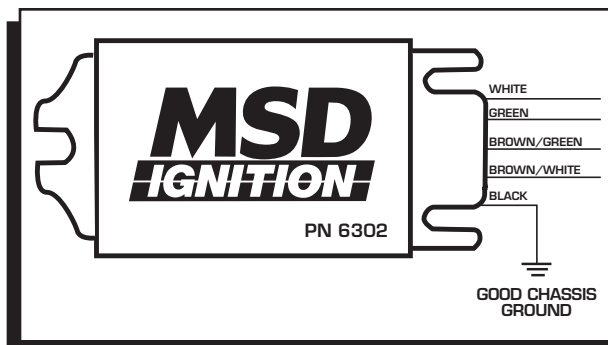

WIRING	
WHITE	Factory ECU Signal A.
GREEN	Factory ECU Signal B.
BROWN/WHITE	Output to DIS A.
BROWN/GREEN	Output to DIS B.
BLACK	Chassis ground.

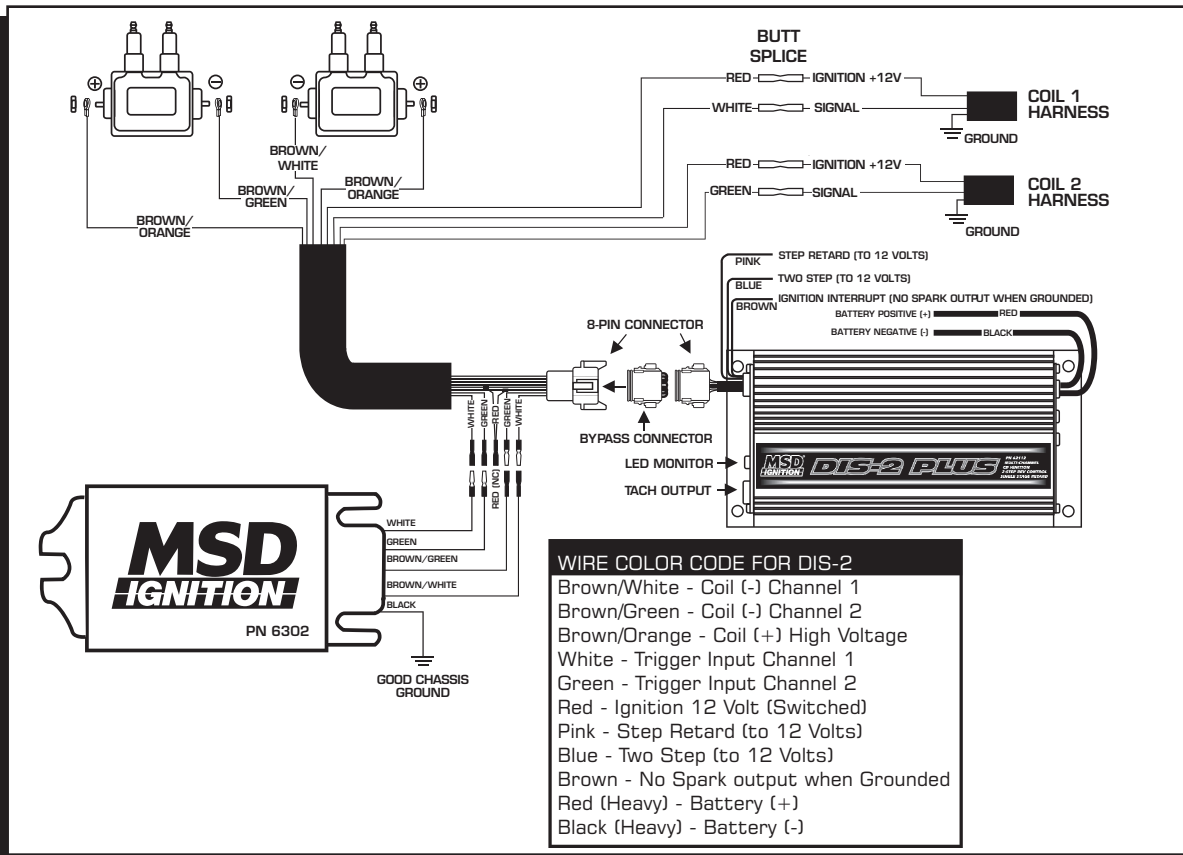

**Figure 1 Wiring**

### Service

In case of malfunction, this MSD component will be repaired free of charge according to the terms of the warranty. When returning MSD components for warranty service, **Proof of Purchase** must be supplied for verification. After the warranty period has expired, repair service is based on a minimum and maximum fee.

**All returns must have a Return Material Authorization (RMA) number** issued to them before being returned. To obtain an RMA number please contact MSD Customer Service at 1 (888) MSD-7859 or visit our website at [www.msdisignition.com/rma](http://www.msdisignition.com/rma) to automatically obtain a number and shipping information.

When returning the unit for repair, leave all wires at the length in which you have them installed. Be sure to include a detailed account of any problems experienced, and what components and accessories are installed on the vehicle. The repaired unit will be returned as soon as possible using Ground shipping methods (ground shipping is covered by warranty). For more information, call MSD Ignition at (915) 855-7123. MSD technicians are available from 7:00 a.m. to 6:00 p.m. Monday - Friday (mountain time).

### Limited Warranty

MSD IGNITION warrants this product to be free from defects in material and workmanship under its intended normal use\*, when properly installed and purchased from an authorized MSD dealer, for a period of one year from the date of the original purchase. This warranty is void for any products purchased through auction websites. If found to be defective as mentioned above, it will be repaired or replaced at the option of MSD Ignition. Any item that is covered under this warranty will be returned free of charge using Ground shipping methods.

This shall constitute the sole remedy of the purchaser and the sole liability of MSD Ignition. To the extent permitted by law, the foregoing is exclusive and in lieu of all other warranties or representation whether expressed or implied, including any implied warranty of merchantability or fitness. In no event shall MSD Ignition or its suppliers be liable for special or consequential damages.

\*Intended normal use means that this item is being used as was originally intended and for the original application as sold by MSD Ignition. Any modifications to this item or if it is used on an application other than what MSD Ignition markets the product, the warranty will be void. It is the sole responsibility of the customer to determine that this item will work for the application they are intending. MSD Ignition will accept no liability for custom applications.